

Prosody, Syntax, and Information Structure III

***September 14-15, 2007 — Indiana University,
Bloomington***

Prosodic Categories and Recursion

Junko Ito & Armin Mester

University of California, Santa Cruz

Road map of this talk

- The standard architecture of phrasal phonology
- Trimming the hierarchy: **one** phrasal category
- Maximal/minimal projections
- Prosodic recursion: “MiP” and “MaP” are projections, not categories

Case studies:

1. Prosodic typology of Japanese compounds
2. Japanese phrasal categories: recursion instead of multiple category layers
3. Maximal vs. non-maximal ω in English

The standard architecture of phrasal phonology

A rich and multi-level hierarchy of categories

- Designed to serve as domains for phonological processes in various languages.
- The underlying research program has valued the postulation of new descriptive categories over restrictiveness.

The standard architecture of phrasal phonology

- Claim here: From a cross-linguistic perspective,
- the prosodic hierarchy has too many categories—
- but still too little structure.

Proposal

- A radical simplification on the categorial side is possible,
- given a better understanding of the relational side of prosodic structure:
- minimal vs. maximal projections
- heads vs. non-heads

The prosodic hierarchy

There is general agreement regarding ...

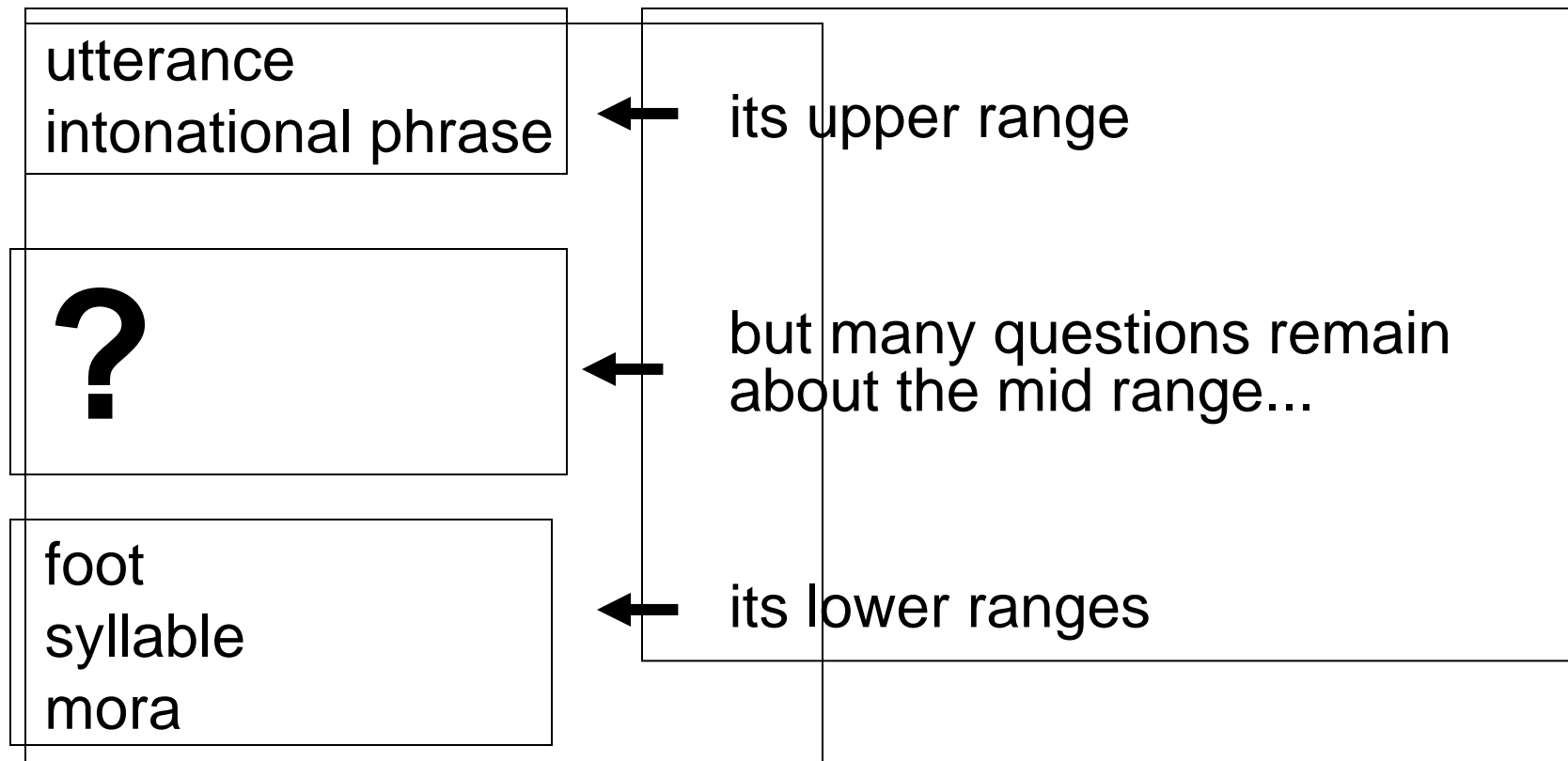

Utterance-level prosody



- The relation between υ and ι requires further study (more later).

Utterance-level prosody

- The exact definition of the intonational phrase has proven difficult,
- beyond the absolutely obligatory ι -parse of root clauses (Downing 1970).
- This is due to the large number of alternative parses and the multitude of factors influencing them.

Utterance-level prosody

- The basic picture is fairly clear since Chomsky and Halle 1968:

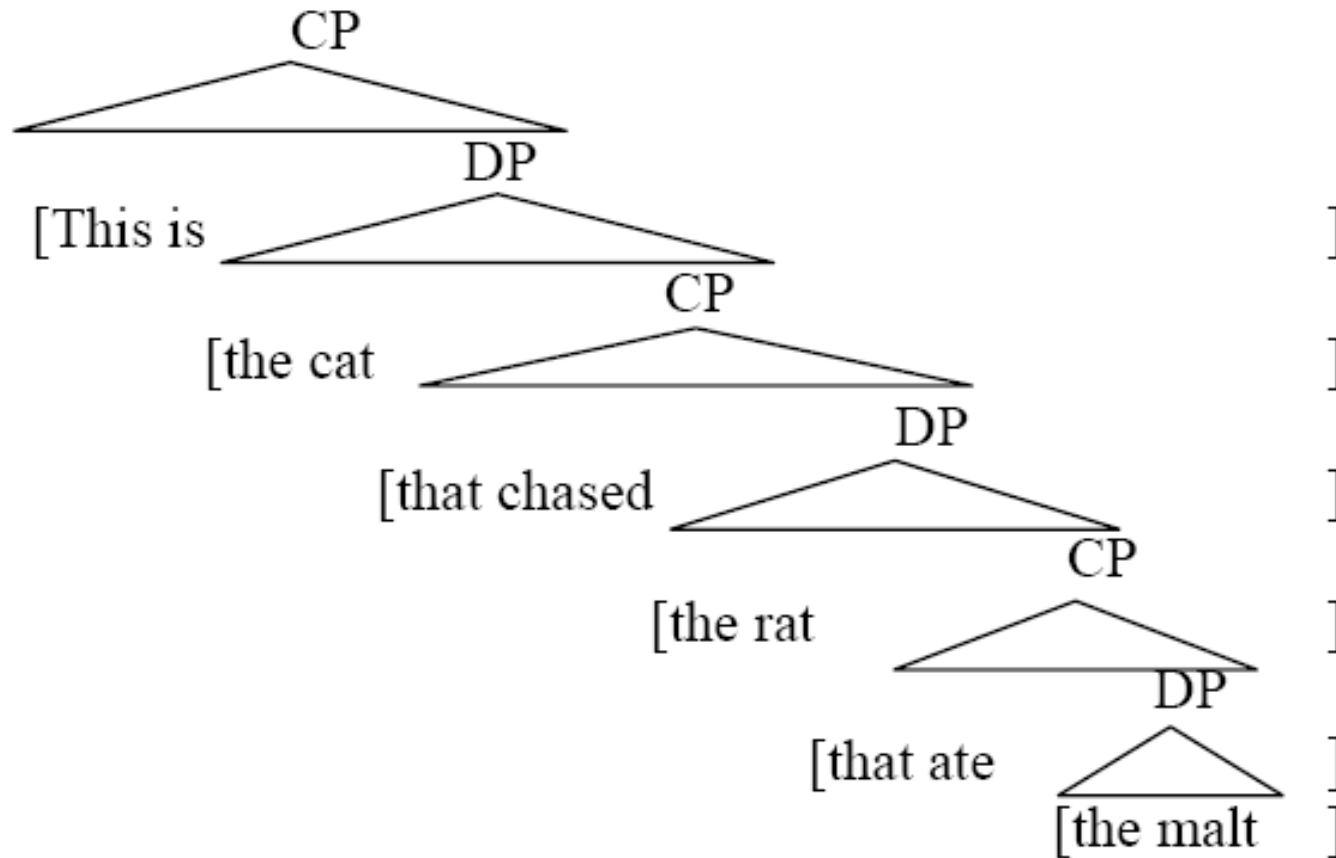

Utterance-level prosody

- This stretch of speech breaks, in a normal style of pronunciation, into a sequence of three ι :

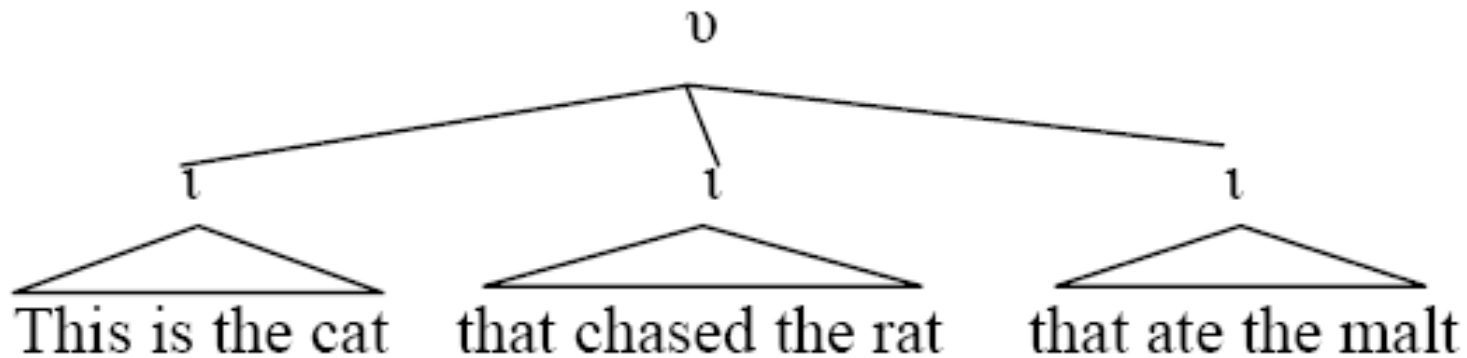

Word-internal prosody

ω prosodic word

|

F foot

|

σ syllable

|

μ mora

Word-internal prosody

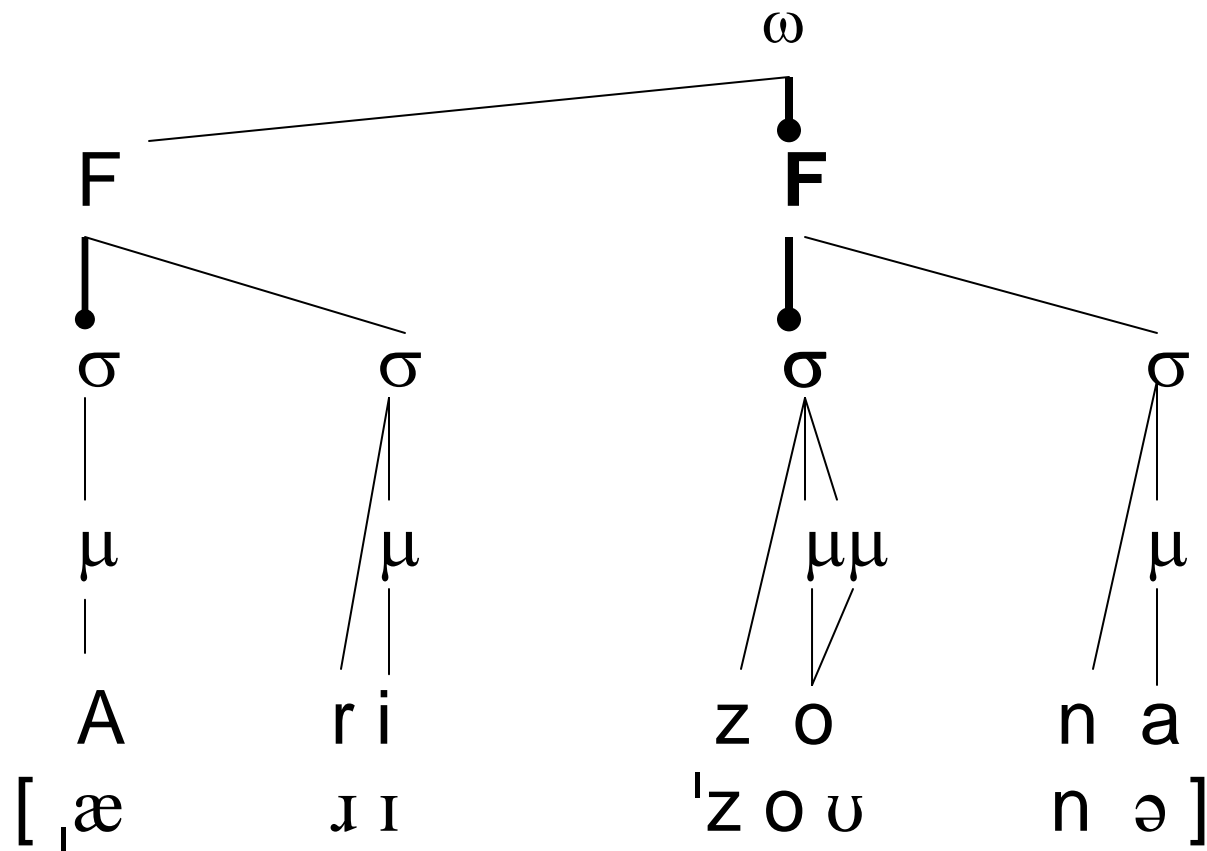

Phrase-level prosody

- The picture is less clear at the phonological phrase level, in the area between intonational phrase and prosodic word.

utterance
intonational phrase

?

foot
syllable
mora

Phrase-level prosody

- The standard view (due to Selkirk, Kubozono, Nespor & Vogel, Hayes, Beckman & Pierrehumbert, among others):
- Several different prosodic categories need to be distinguished in order to provide enough separate domains for different processes.

Many phrasal categories proposed

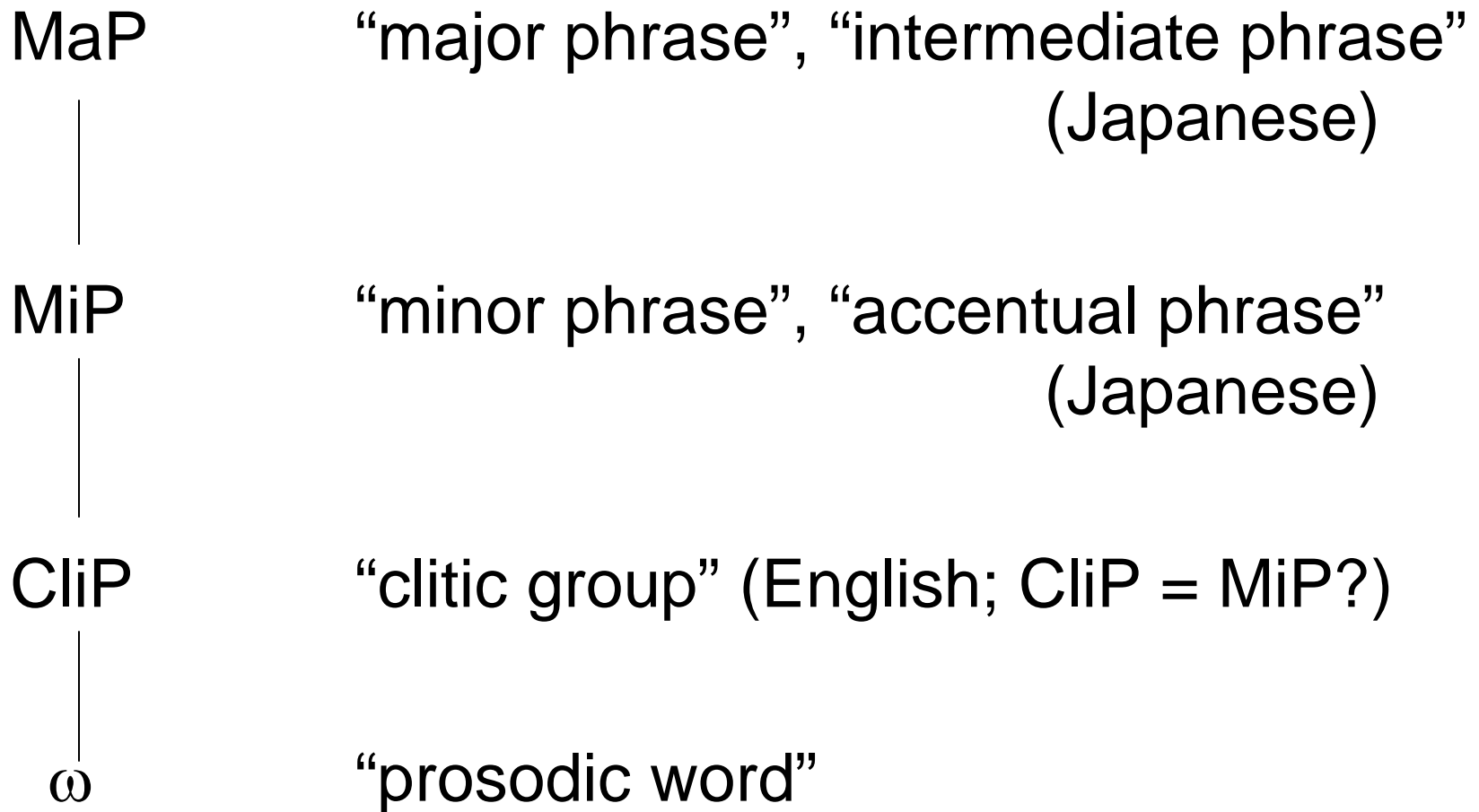

Problems with the standard view

- I. Language-specific gaps in the hierarchy
- II. Lack of cross-linguistic identification
- III. Language-specific definitions

I: Language-specific gaps

- A natural requirement for a universal hierarchy should be that its elements are present in all languages—otherwise it is not a universal hierarchy.
- But in the prosodic hierarchy, a number of language-specific gaps have been postulated for particular languages.

I: Language-specific gaps

- For example, Japanese has been claimed to have only a single category corresponding to
 - both ν and ι
 - (Pierrehumbert and Beckman 1988),
 - and even to ν , ι , and φ
 - (J-ToBI, see Venditti 1997).

I: Language-specific gaps

- Cf. the parallel situation in syntax:
- Language-specific absence of categories has also been considered, often on prima-facie plausible grounds.

I: Language-specific gaps

- Take the standard view that a simple sentence in a VSO language still has a VP constituent
- grouping together V and O, to the exclusion of the intervening S.
- This is not what naïve inspection of surface string VSO suggests.
- It was a reasonable hypothesis that the grammar of such a language might not have a VP constituent.

I: Language-specific gaps

- Subsequent research has shown, however, that this kind of language-specific gap in the syntactic hierarchy simply does not exist.
- Evidence for the purportedly missing VP turned out to be plentiful once seriously sought after (e.g., McCloskey 1983 for Irish, a VSO language).

I: Language-specific gaps

Saito 1985 (among others):

- The absence of a VP node is not what characterizes “non-configurational” languages such as Warlpiri, Tohono O'odham (Papago), or Japanese.
- VP is universally present.
- The explanation for non-configurational properties lies elsewhere.

I: Language-specific gaps

- Returning to prosody:
- Kawahara and Shinya 2006 have argued that there is indeed evidence supporting a distinction between υ , ι , and φ in Japanese, as predicted by the assumption of universality.
- But the general problem persists.

I: Language-specific gaps

- Possible diagnosis: The universal hierarchy might be **overdifferentiated**.
- **“Too many categories”**
- This makes it necessary to eliminate certain levels of prosody whenever the facts in a given language do not seem to support it.

I: Language-specific gaps

- Insist on the universal presence of all categories in all grammars?
- Problematic in the absence of any audible cues.

II: Cross-linguistic identification of categories

- How can we reliably identify categories across languages?
- In syntax, it is not hard to identify, e.g., the DP constituents in language A,
- and to set them in correspondence with the DPs of language B—

II: Cross-linguistic identification of categories

- Identification is possible despite all kinds of differences in morphosyntax, word order, zero anaphora, etc.
- Reason: There is a set of core syntactic and semantic properties shared by the DPs of all languages.

II: Cross-linguistic identification of categories

- Similarly for word-internal prosodic units (syllables and feet):
- E.g., the foot—a unit of abstract linguistic rhythm taken from a very small inventory of rhythmic types (Hayes 1995).

II: Cross-linguistic identification of categories

- Feet can be identified in languages whether they have word stress or not, whether they have multiple stress peaks per word or just one, etc.
- Reason: These units are intrinsically defined by properties that recur in all of their instantiations.

II: Cross-linguistic identification of categories

- This identification is much harder for the higher units of the hierarchy, beginning with the prosodic word.
- Does the α -phrase of language A correspond to the α -phrase of language B?
- Or to the β -phrase of B?
- Or is there no correspondent in B?

II: Cross-linguistic identification of categories

Reason for the difficulty:

- Lack of truly cross-linguistically valid and constant properties associated with these higher prosodic units
- Related discussion in Beckman & Pierrehumbert 1986, Selkirk 2005 and Truckenbrodt 2006.

III: Language-specific definitions

- Categories are sometimes literally defined in terms of the processes associated with their instantiations in specific languages.
- This results in labels like "accentual phrase", "tone group", etc.

III: Language-specific definitions

- This is a natural step for the description of a single language.
- However, it creates additional identification problems for categories between languages and grammars.

III: Language-specific definitions

- The processes are of course specific to each language
 - though hopefully explicable as arising through the interaction of universal constraints, as in OT phonology
- But the domains themselves need to be a universal set of categories.

Proposal here

| | | |
|---|------------------|-------------------------------|
| υ | utterance | <i>upper-range categories</i> |
| ι | intonation group | |

| | | |
|---|--------|--|
| φ | phrase | <i>mid-level categories:</i> Universal phonology provides only TWO categories |
| ω | word | |

| | | |
|---|----------|---------------------------------|
| F | foot | <i>word-internal categories</i> |
| σ | syllable | |
| μ | mora | |

Proposal here

- Additional layers arise through prosodic adjunction to these two categories (recursion).
- They do not constitute further distinct categories.
- Without recursion, the theory provides **too little structure.**

Prosodic recursion

- φ -adjunction

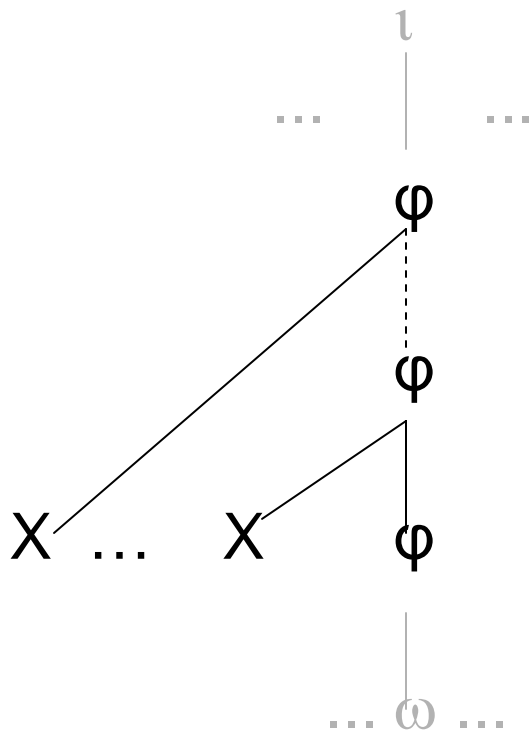

- ω -adjunction

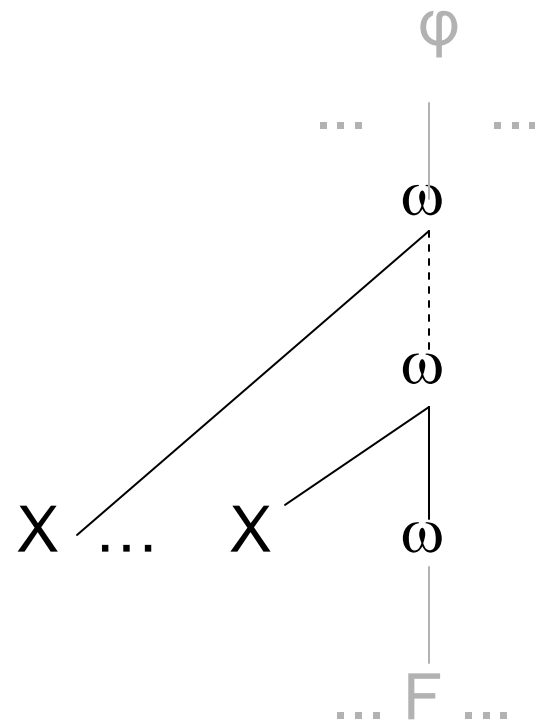

Recursion in prosodic structure

- Ladd (1986, 1988) shows that nested coordinate constructions form recursive ι -structures:

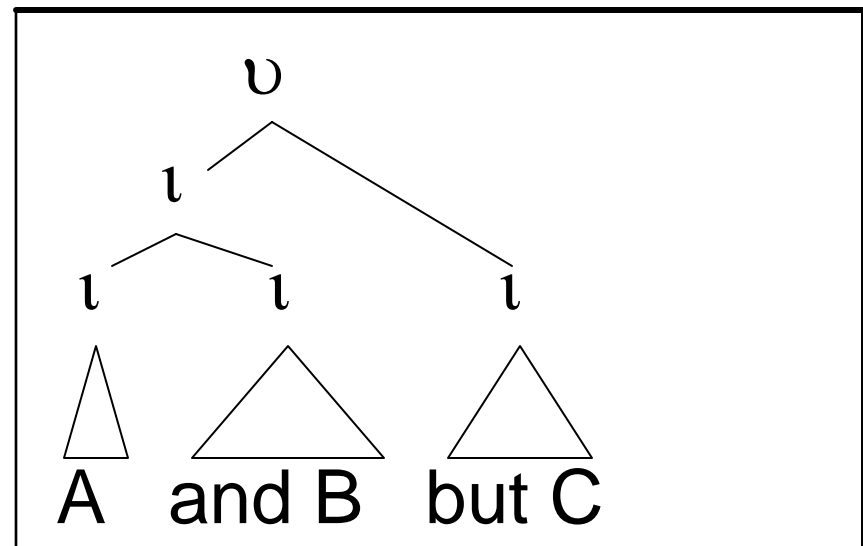
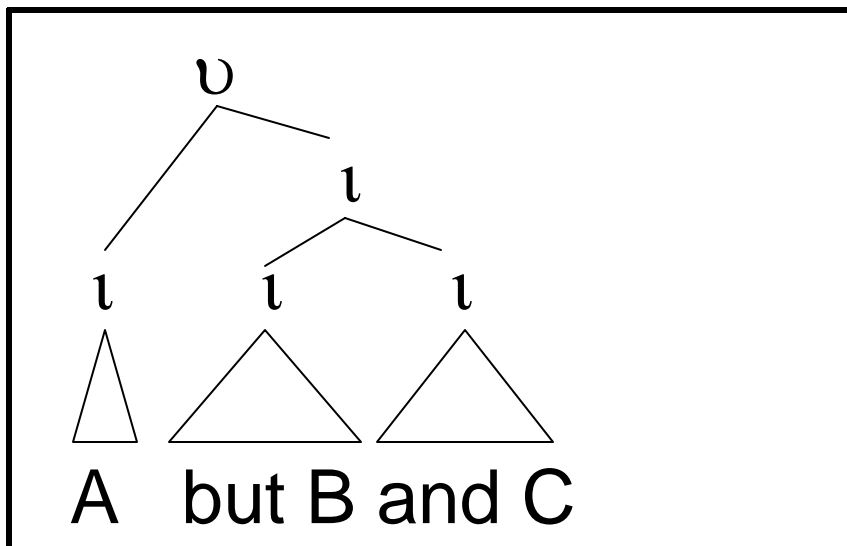

Recursion I: Intonational phrase

- Clinton has a lot more money, (but Obama is a stronger campaigner, and Edwards has a more popular program.)
- (Obama is a stronger campaigner, and Edwards has a more popular program,) but Clinton has a lot more money.

Syntactic structure

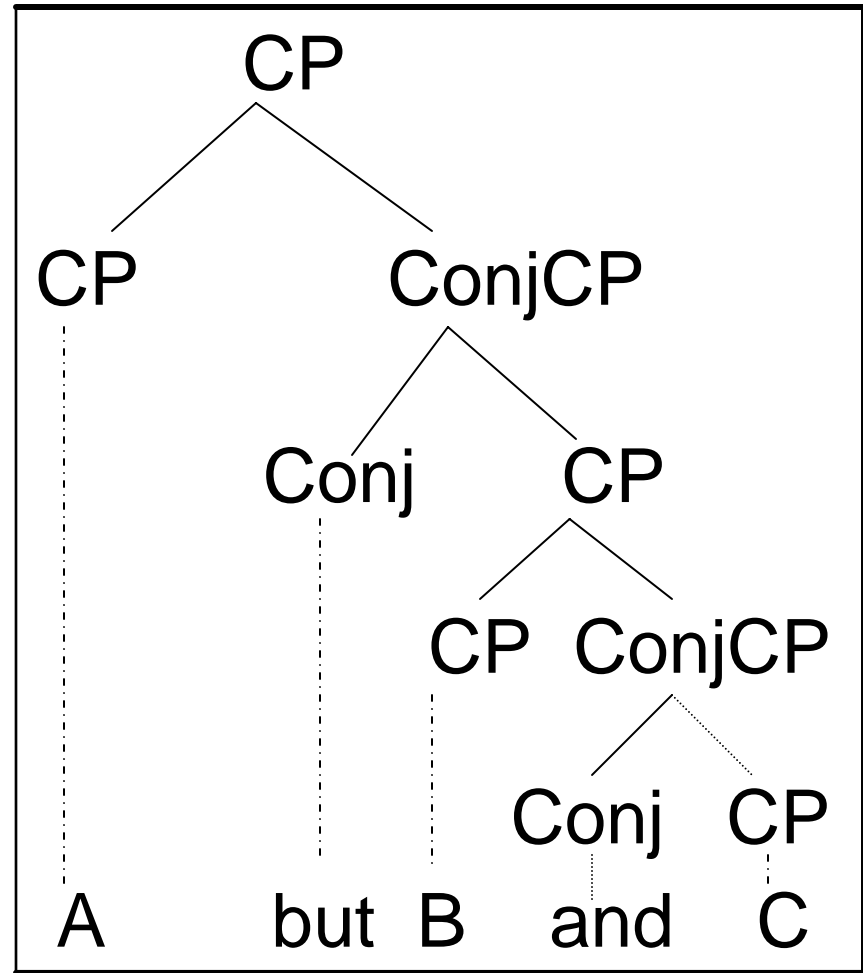
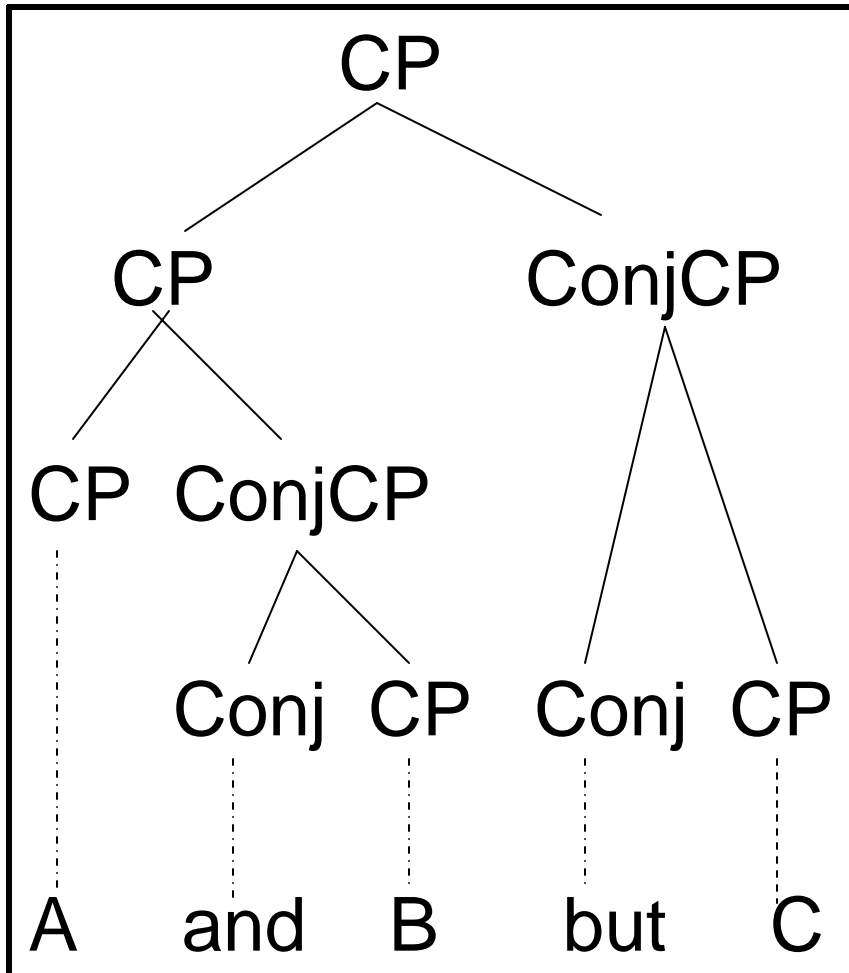

Evidence: Scaling of downstep

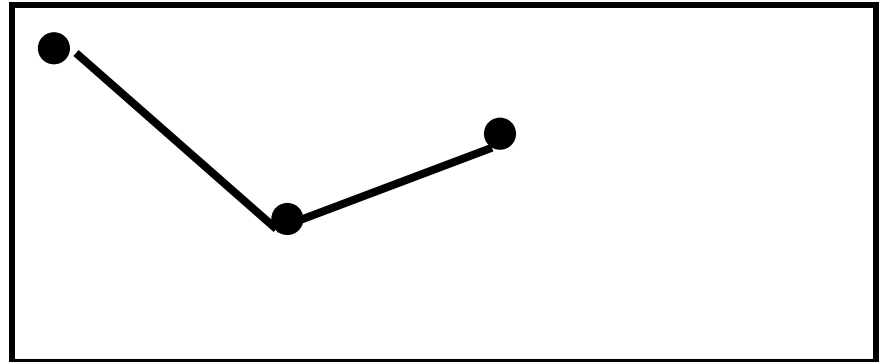
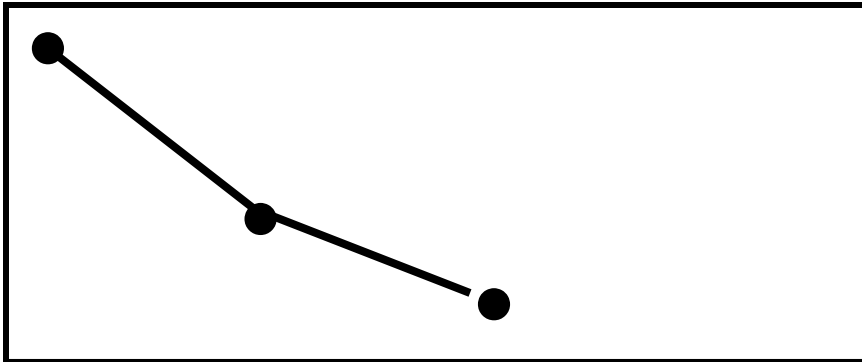
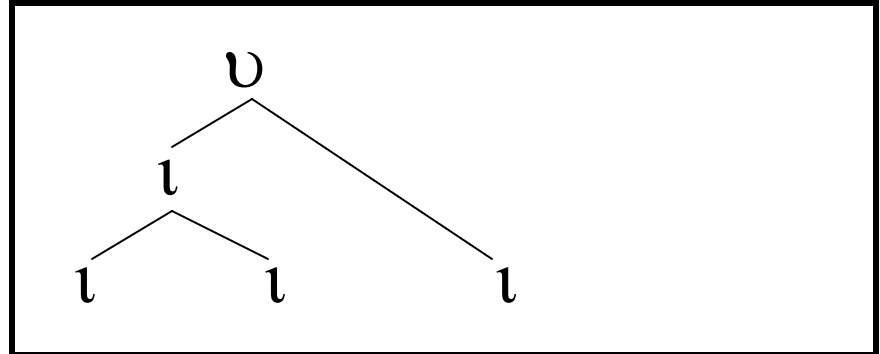
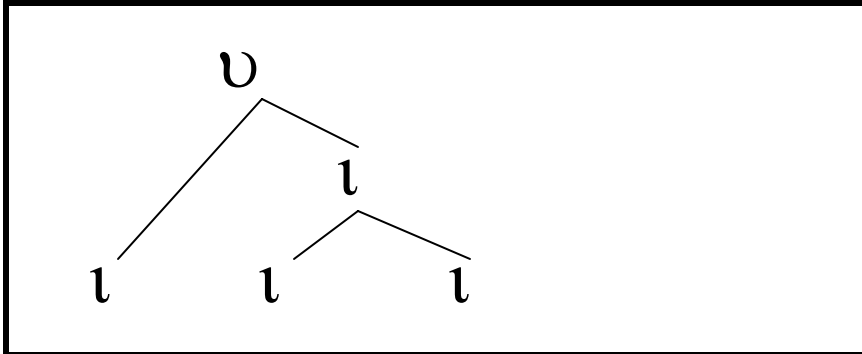

A but (B and C)

(A and B) but C

(schematized pitch contours)

Downstep in recursive coordinate structures

- Within each level of coordination, the second conjunct is downstepped with respect to the first conjunct.
- “Downstep”: The highest peak in the second conjunct is lower than the highest peak in the first conjunct.

A but (B and C)

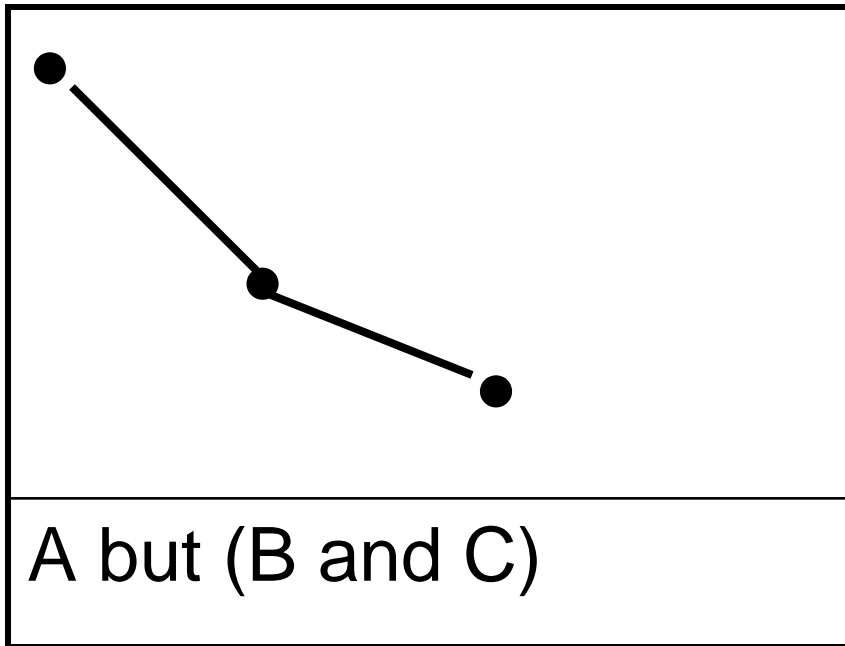

- *B* is downstepped relative to *A*,
- *C* is downstepped relative to *B*.

(A and B) but C

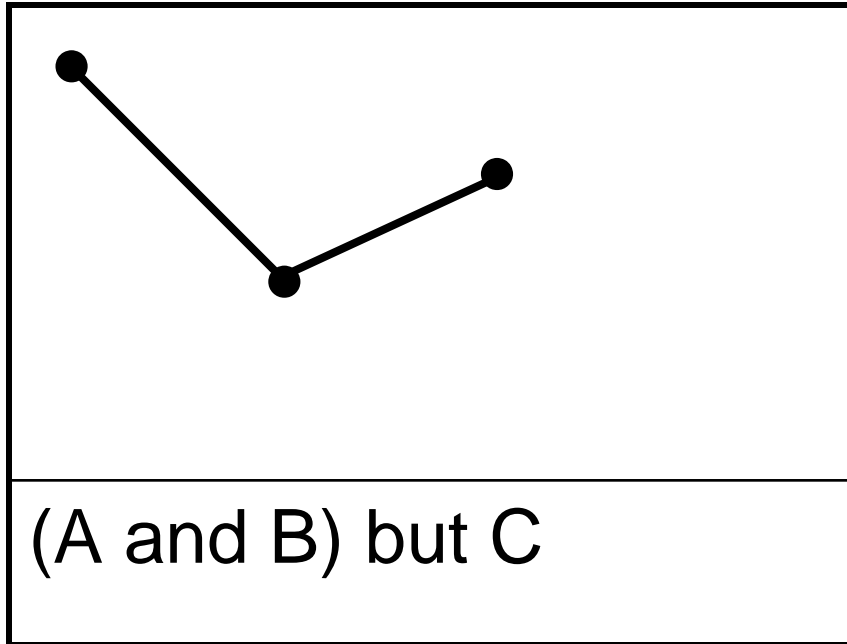

- *B* is downstepped relative to *A*.
- *C* is downstepped relative to the conjunct *A and B*, i.e., relative to *A*, the highest peak;
- *C* is not downstepped relative to *B*.

Recursion II: phonological phrase

- Background assumption: The “Rhythm Rule” amounts to “early pitch accent placement”.
- It signals the left boundary of a phonological phrase. (Gussenhoven 1991, Shattuck-Hufnagel, Ostendorf, and Ross 1994).

Rhythm Rule in Dutch

★ ∅ ★

[_φ àardrijkskundig genóotschap]
‘geographical society’

★
cf. aardrijkskúndig

Recursion II: phonological phrase

- The option of having of **multiple instances** of the Rhythm Rule in complex phrases indicates recursive phonological phrasing.

(Schreuder and Gilbers 2004, Schreuder 2006).

Recursion II: phonological phrase

- Gussenhoven 2005 proposes recursive φ -structures for English prenominal modifier constructions:

Twènty-six gòod-looking Jàpanese D'Js

- Main argument:
- Their Rhythm Rule behavior shows that they are procliticized: preceded, but not followed, by a φ -boundary.

Recursion II: phonological phrase

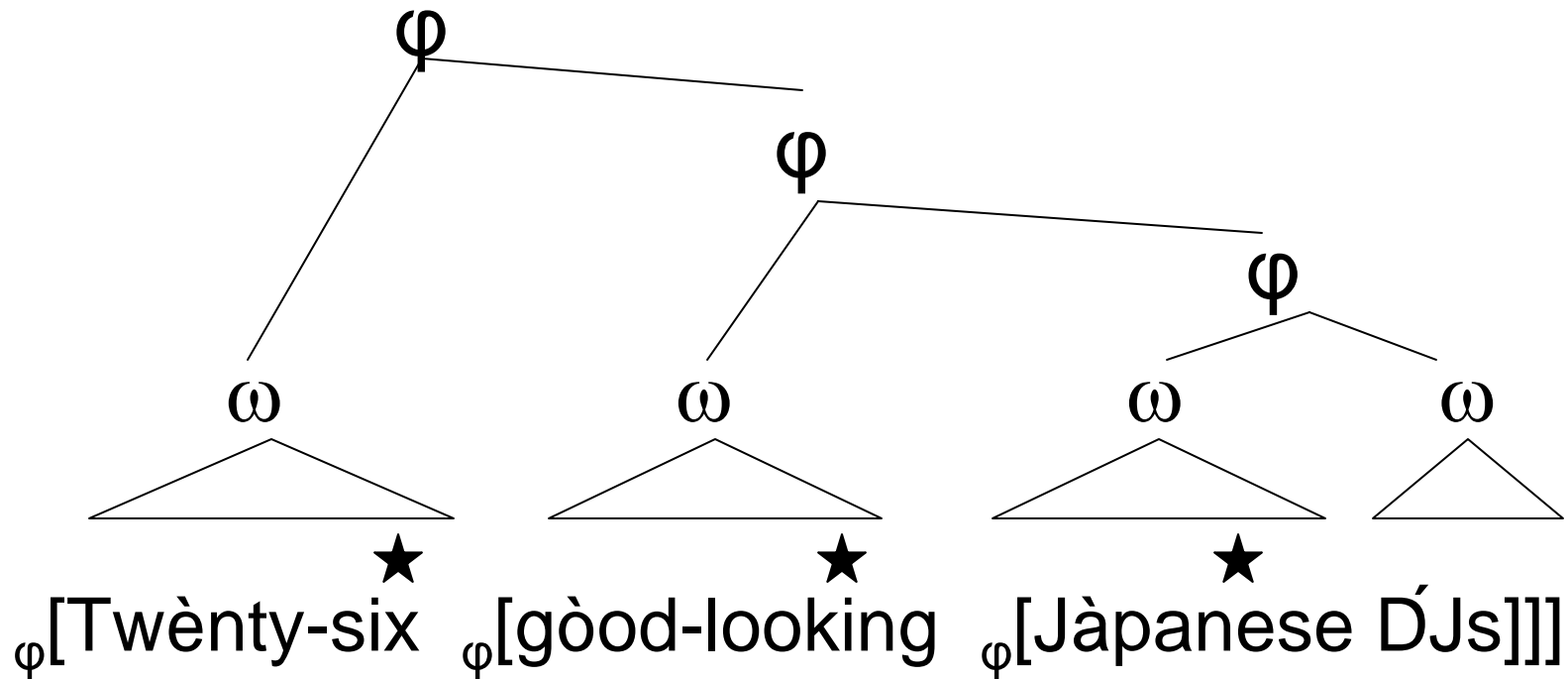

Other work

- Further development, with additional evidence, in Kubozono (1988/93, 2005), van den Berg, Gussenhoven, and Rietfeld 1992, Truckenbrodt 2002, and Féry and Truckenbrodt 2005.
- Extensive study and motivation of recursive structures in prosody in two recent dissertations: Wagner 2005 (MIT), Schreuder 2006 (Groningen).

Proposal so far

- (i) Universal Phonology distinguishes only a small number of genuinely separate categories (such as "phrase" and "word").
- (ii) Recursion: Additional layers arise through prosodic adjunction to these categories, they do not constitute further distinct categories.

Relations vs. categories

- (i) Relational side of prosodic structure:
 - Each category defines its own network of projections;
 - The usual tree-structural notions apply, such as "minimal" and "maximal projection".
- (ii) Phonological and phonetic processes:
 - are part of the realization of this structure;
 - signal important boundaries by selecting different constituents as their domains.

Relations vs. categories

- “Minimal”, “maximal”:
- relational notions,
- like—
- “head”, “non-head”;
- “independent” (mora)
“dependent” (mora);
- “subject”, “object”.
- “Phrase”, “word”:
- categorial notions,
- like—
- “syllable”, “mora”;
- “labial”, “coronal”,
“dorsal”;
- “noun”, “tense”.

Maximal and minimal projections

Using standard tree-structural terminology:

- the largest projection of a prosodic category κ is the “maximal κ ”,
- its smallest projection is the “minimal κ ”.
- More formally:

$\kappa_{\max} =_{\text{def}} \kappa$ not dominated by κ

$\kappa_{\min} =_{\text{def}} \kappa$ not dominating κ

Prosodic adjunction: phrase level

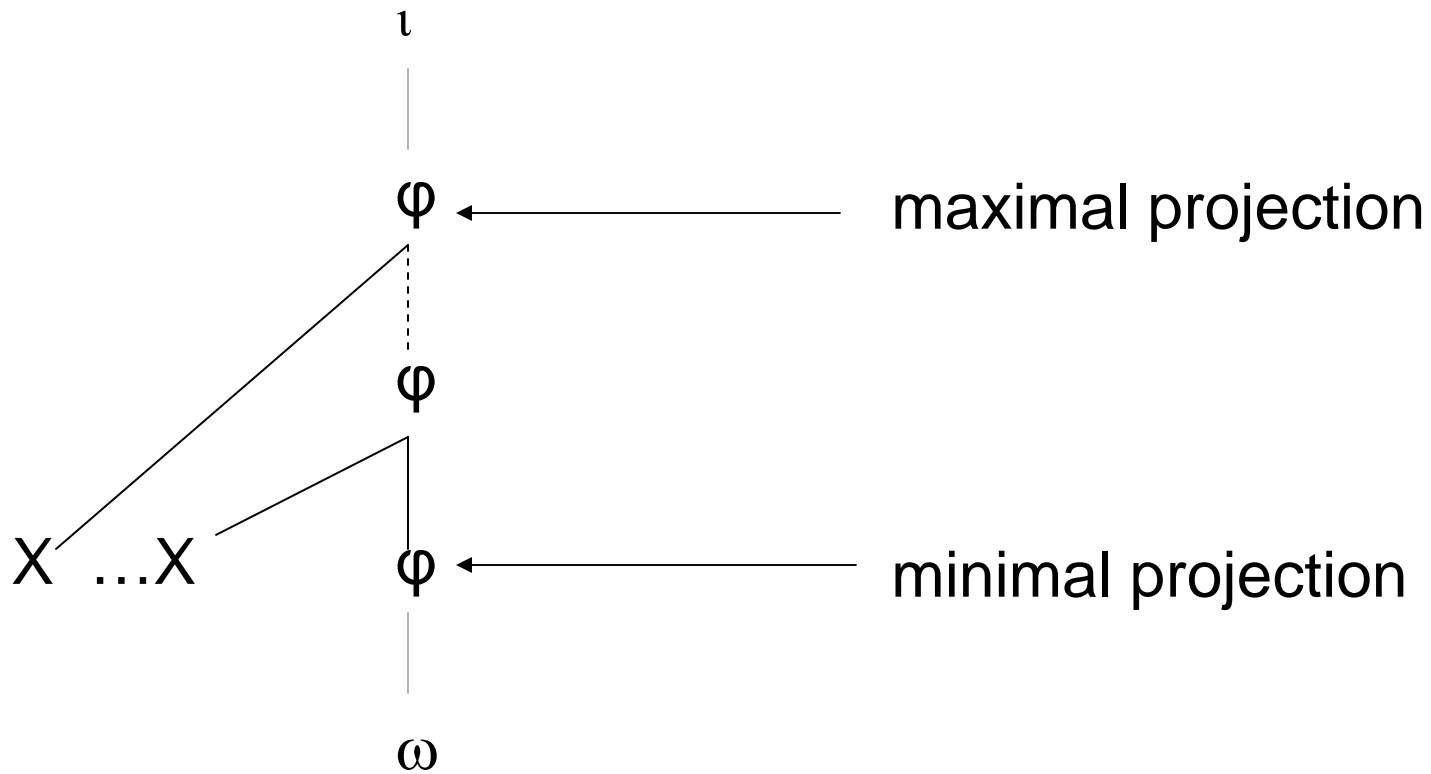

Prosodic adjunction: word level

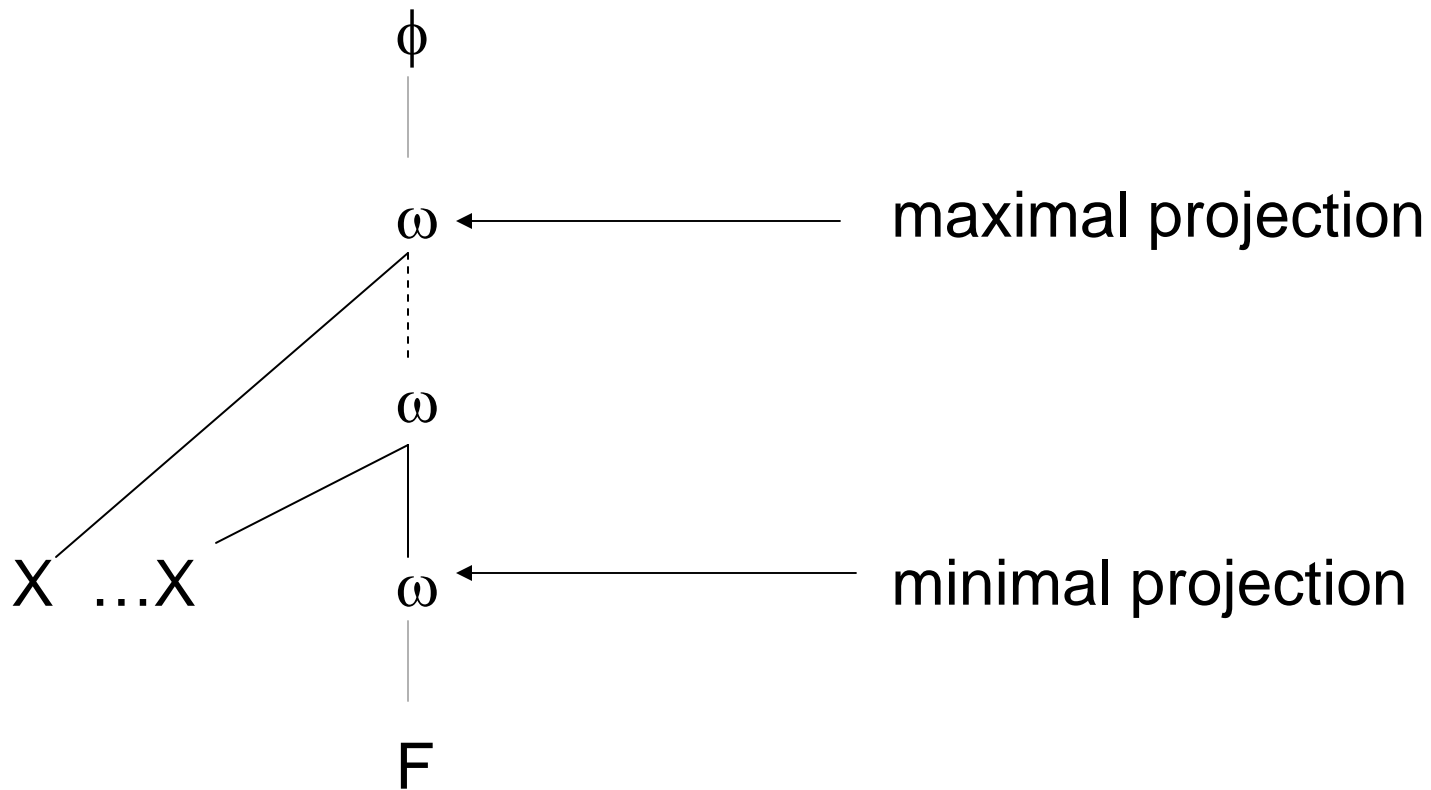

Further extensions

“Utterance” as maximal projection of ι ?

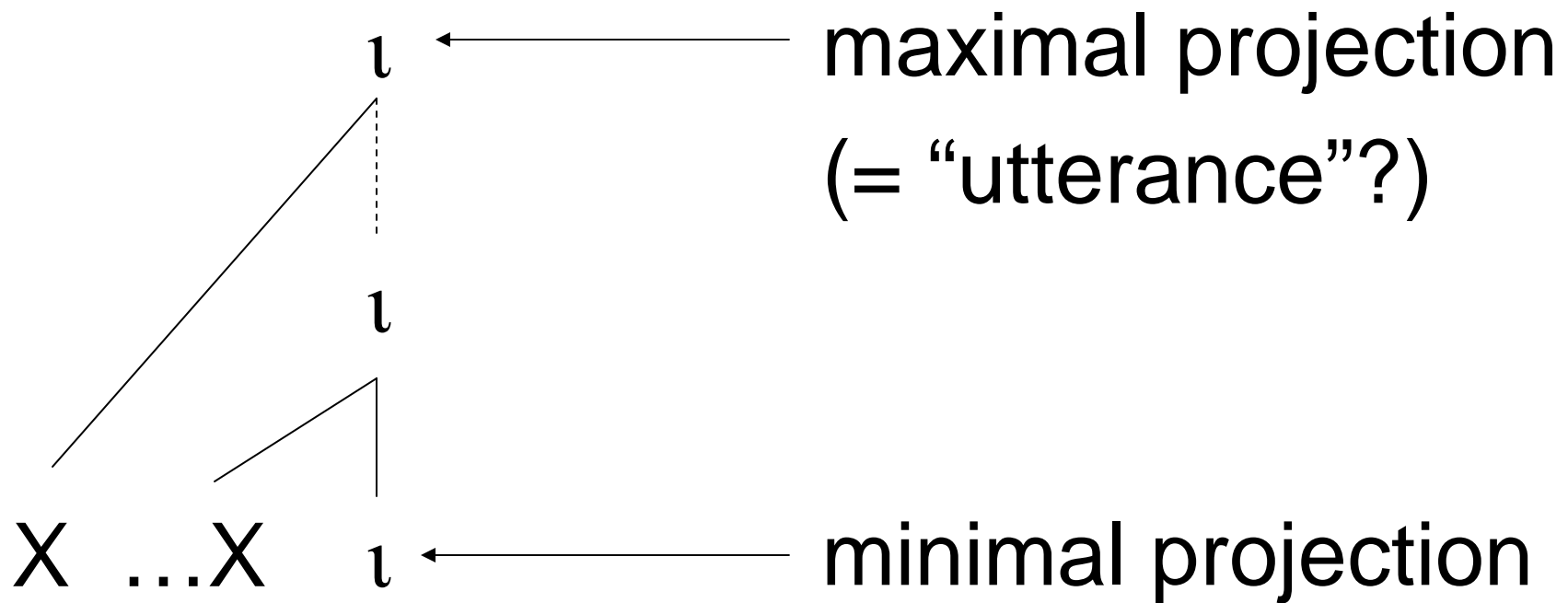

See also Kawahara and Shinya 2006 on ι and υ in Japanese.

Case Study 1:

Typology of Japanese compounds

- Adjunction to φ and ω
- Minimal projections
- Maximal projections
- Heads
- Binarity constraints

Prosodic typology of compounds

| word compounds | phrasal compounds | | |
|---|---|---|--|
| | mono-phrasal | bi-phrasal | |
| <p>A tree diagram for the word compound 'hoken-Gaisha'. The root node is a circled ω. It branches into two ω nodes. The left ω node branches into two ω nodes, which lead to 'hoken' and 'Gaisha' respectively. The right ω node leads to 'bAnare'.</p> | <p>A tree diagram for the phrasal compound 'genkin fUri-komi'. The root node is a circled ω. It branches into two ω nodes. The left ω node leads to 'genkin'. The right ω node branches into two circled ω nodes, which lead to 'fUri' and 'komi' respectively.</p> | <p>A tree diagram for the phrasal compound 'hatsu kao-Awase'. The root node is a circled ϕ. It branches into two ω nodes. The left ω node leads to 'hatsu'. The right ω node branches into two ω nodes, which lead to 'kao' and 'Awase' respectively.</p> | <p>A tree diagram for the bi-phrasal compound 'zEnkoku kaisha-Annai'. The root node is a circled ϕ. It branches into two circled ϕ nodes. The left circled ϕ node branches into a ω node, which leads to 'zEnkoku'. The right circled ϕ node branches into two ω nodes, which lead to 'kaisha' and 'Annai' respectively.</p> |

Properties of branching compounds

| Compound Type | word compounds | | phrasal compounds | |
|--------------------------|----------------|------------|-------------------|-----------|
| | | | | |
| rendaku | Yes | No | No | No |
| junctional accent | Yes | Yes | No | No |
| deaccenting | Yes | Yes | Yes | No |

Minimal and maximal projections of ω

| word compounds | phrasal compounds | | |
|---------------------------------|------------------------------|-----------------------------|----------------------------------|
| | mono-phrasal | bi-phrasal | |
| <p>hoken-Gaisha bAnare</p> | <p>genkin fUri-komi</p> | <p>hatsu kao-Awase</p> | <p>zEnkoku kaisha-Annai</p> |

Minimal ω -projections : rendaku

- Rendaku is restricted to minimal ω -projections.
- It is excluded in higher projections—i.e., in positions which simultaneously initiate two ω -constituents.

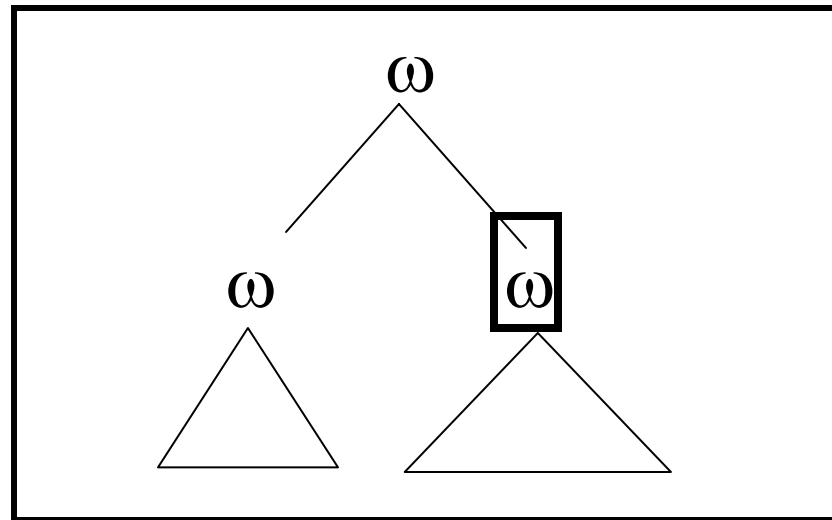

Maximal ω -projections: junctural accent

- Junctural accent is found in word compounds, not in phrasal compounds.
- The locus of the compound accent is the internal juncture of a maximal ω .

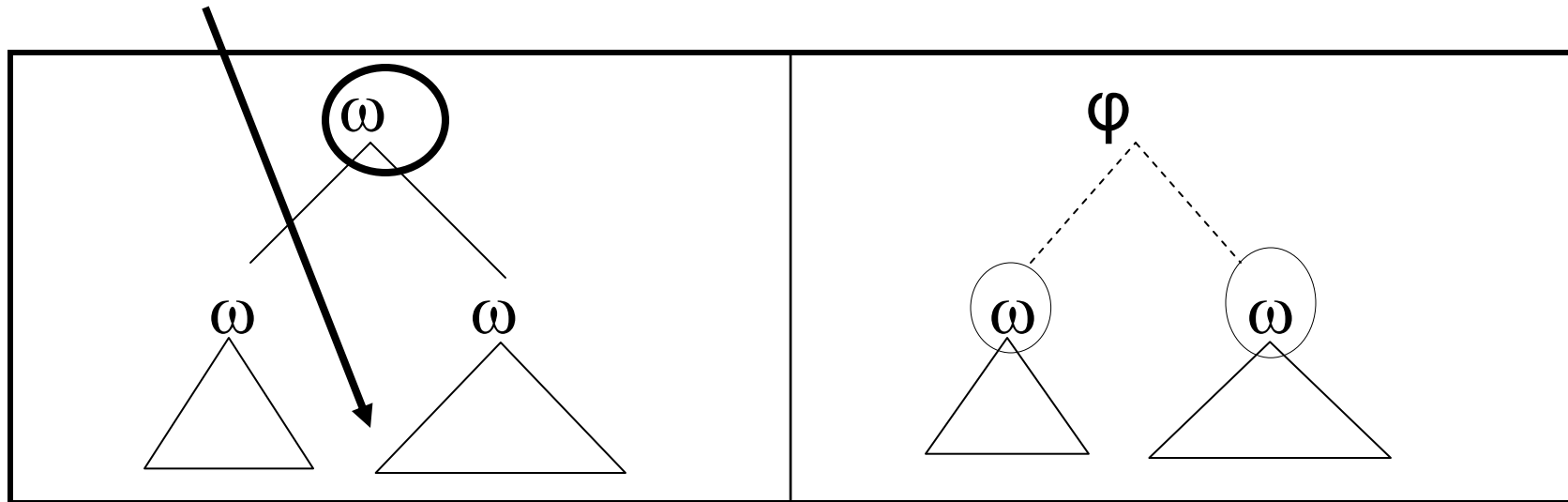

Minimal φ -projections: deaccentuation

deaccentuation of dependent (non-head) member
within minimal φ

mono-phrasal

bi-phrasal

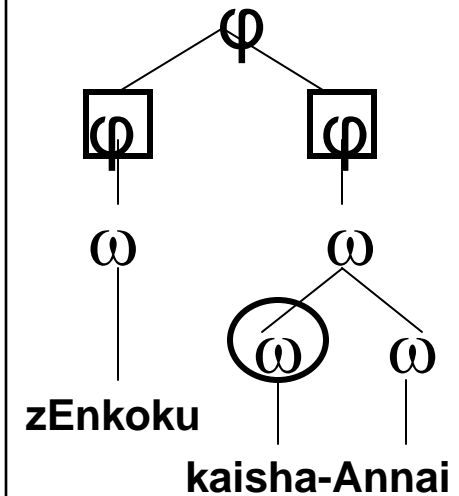
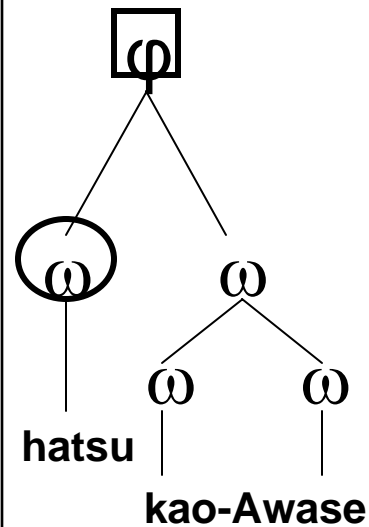
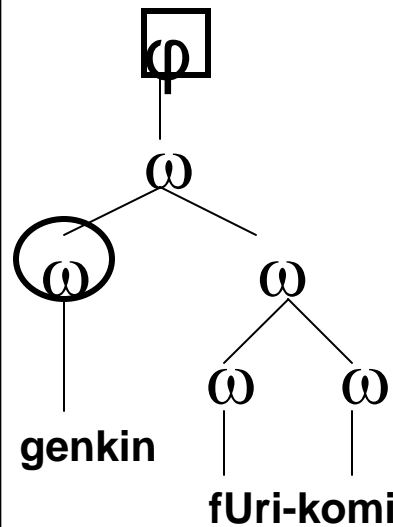
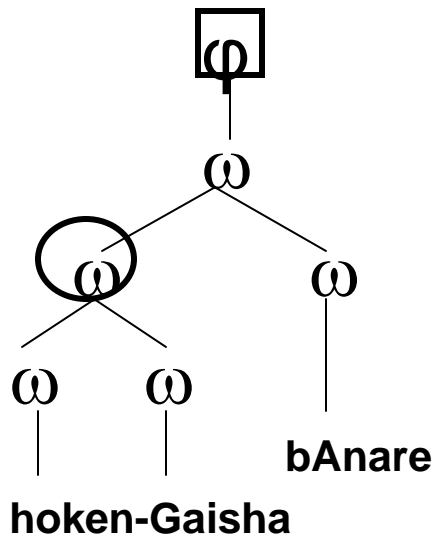

Summary

projection:

- minimal ω
- maximal ω
- minimal φ
- φ (any φ)

domain of:

- ✓ rendaku
- ✓ junctural accent
- ✓ deaccentuation
- ✓ downstep, initial lowering

Why ω [$\omega\omega$] versus ϕ [$\omega\omega$] ?

- Recall: Word compounds ω [$\omega\omega$] have junctural accent, phrasal compounds ϕ [$\omega\omega$] do not.
- What determines whether a compound is a word compound ω [$\omega\omega$] or a phrasal compound ?
- Prosodic length factor (Kubozono, Ito and Mester 1997):

Why ω [$\omega\omega$] versus ϕ [$\omega\omega$] ?

- If the head (second member) exceeds two bimoraic feet (4μ), the whole form is parsed as a phrasal compound.

head $\leq 4\mu$: ω [nankyoku-tÁnken]
'Antarctic exploration'

head $>4\mu$: ϕ [*nankyoku-tankentai*]
'Antarctic expedition'

4 μ size limit for canonical words

- (i) Most frequent word type in the lexicon (Sakano 1996, Kozasa 2000).
- (ii) 4 μ -words show a strong tendency to be unaccented, where unaccentedness has been interpreted as a sign of unmarkedness (Tanaka 2001).

4 μ size limit for canonical words

- (iii) Significant difference in the amount of final lengthening between 4 μ -sequences that constitute phonological words vs. longer sequences (Mori 2002).
- (iv) A 4 μ -template defines the maximal size of Japanese truncations (Ito 1990, Ito and Mester 1992) and language game forms (Tateishi 1989, Ito, Kitagawa and Mester 1996).

Prosodic length limit

- Two-foot limit as a consequence of a constraint requiring words to be prosodically binary (Ito and Mester 1992, Ussishkin 2000, 2005, and others).
- With bimoraic foot parsing, any form longer than four moras ends up with more-than-binary branching: $[(\mu\mu)_1(\mu\mu)_2\mu_3]$, etc.

Maximal and minimal prosodic size constraints

- For a prosodic category κ , we distinguish $\text{MaxBin}(\kappa)$ and $\text{MinBin}(\kappa)$.
(Mester 1994, 6-8, Hewitt 1994, and Selkirk 2000, 244)
- As a derivative constraint, we refer to their combination as $\text{Bin}(\kappa)$.
- For $\kappa = \sigma, F, \omega, \varphi$, etc., this yields a family of (independently rankable) constraints.

Binarity constraints

Schema for binarity constraints

| | | |
|-------------------------------|-------------------------------|-----------------------------|
| MaxBin(κ) | MinBin(κ) | Bin(κ) |
| κ is maximally binary. | κ is minimally binary. | κ is exactly binary. |

Family of binarity constraints

| | | |
|--|--|-------------------------------------|
| MaxBin($\sigma, F, \omega, \varphi$) | MinBin($\sigma, F, \omega, \varphi$) | Bin($\sigma, F, \omega, \varphi$) |
|--|--|-------------------------------------|

Evaluation of $\text{MaxBin}(\omega)$

Fulfills $\text{MaxBin}(\omega)$

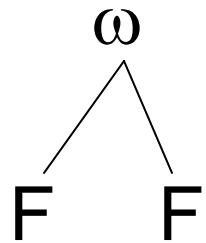

(kasu)(tera)

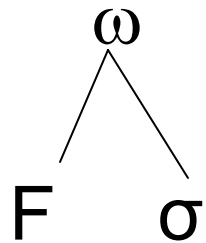

(tere) bi

Violates $\text{MaxBin}(\omega)$

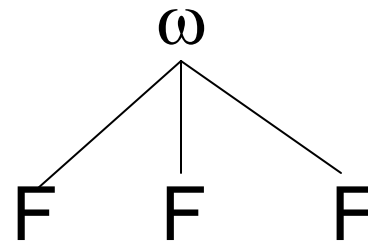

(asu)(para)(gasu)

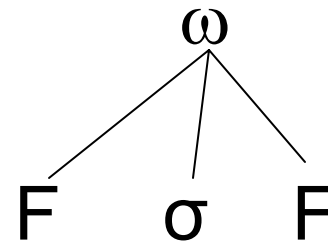

(kuri)su(masu)

OT analysis

- Constraints enforcing canonicity (here, binarity constraints) have specific instantiations for heads.
- → an instance of positional markedness
- MaxBin(Head(ω)): Heads of prosodic words are maximally binary.
- Result: Adjunction is only possible to canonical words.

OT analysis

Ranked constraints:

Align-Left (ω , MWd):

ω must begin a MWd.

|

MaxBin(Head(ω)):

ω -heads must be
maximally binary.

|

Wrap (MWd, ω):

MWd constitutes a ω .

Violation of ω -head binarity yields phrasal compounds

| | / hatu - kao awase / | AI-L | MxBinHd ω | Wrap |
|---|----------------------|------|------------------|----------|
| | | | *! | |
| ➡ | | | | * |

Fulfilling ω -head binarity results in word compounds

| | / denki - kami sori / | Align-L | MaxBinHd | Wrap |
|---|-----------------------|---------|----------|------|
| → | | | | |
| | | | | * |

Align-Left forestalls breaking up simplex words

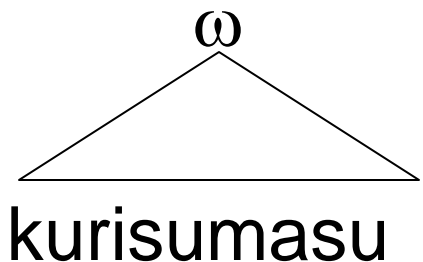
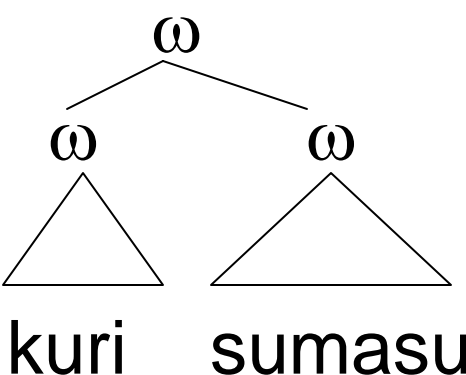
| | / kurisumasu / | Align-Left (ω , MWd) | MaxBinHd | Wrap |
|---|--|---------------------------------|----------|------|
| → |  | | * | |
| |  | *! | | |

Case Study 2: Japanese phrasal categories

- Rich area of previous phonological and phonetic work:
- McCawley 1968, Haraguchi 1977, Poser 1984, Kubozono 1988, Beckman & Pierrehumbert 1986, Selkirk & Tateishi 1988, etc.

Phrasal categories in Japanese

- The standard approach distinguishes two phrasal categories:

MaP major (\approx “intermediate”) phrase

MiP minor (\approx “accentual”) phrase

(ω prosodic word)

Proposal here

- There is only ONE category:

φ (“phrase”)

Question

- The distinction between MiP and MaP is supposed to be irreducible because the two are domains for different processes.
- How can these domains be distinguished if there is only one kind of “phrase”?

Reconsidering the arguments

- MiP:

Domain of accentual culminativity: at most one accent.

MiP as domain of culminativity

There can only be one accent in a Minor Phrase (hence the alternative name “Accentual Phrase”).

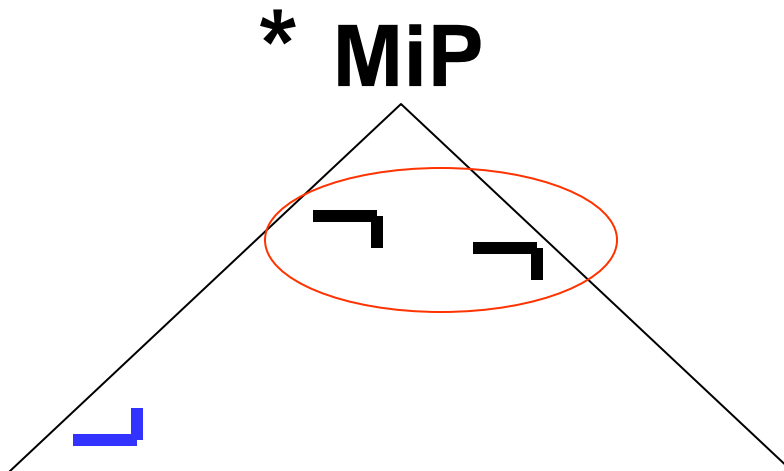

Reconsidering the arguments

- MiP:

Domain of initial lowering: Low tone at left boundary followed by High tone.

Initial lowering within MiP

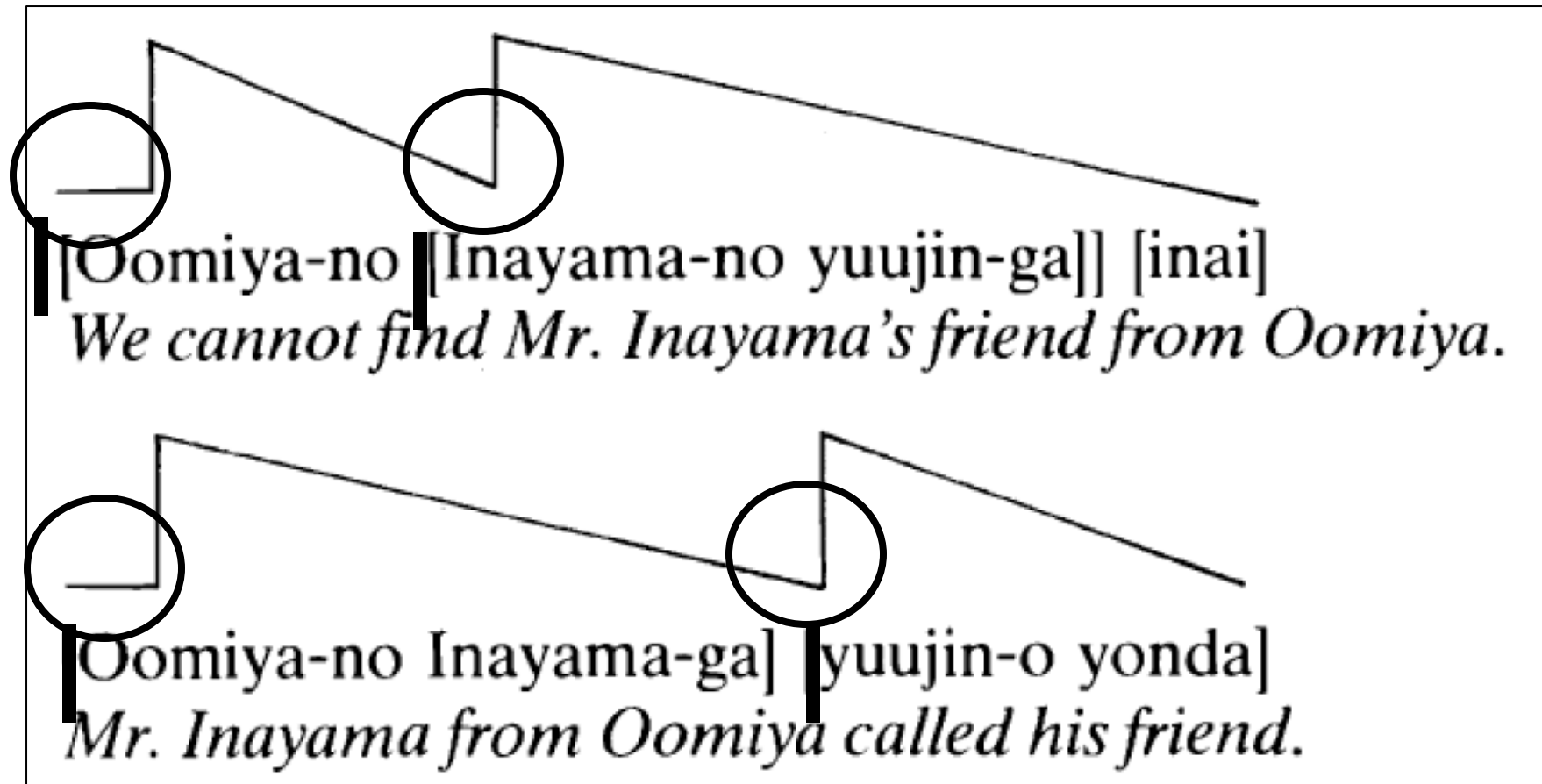

From Selkirk and Tateishi 1991

Reconsidering the arguments

- MaP:

Domain of downstep: Lowering of the pitch register following each accented syllable.

Downstep within MaP

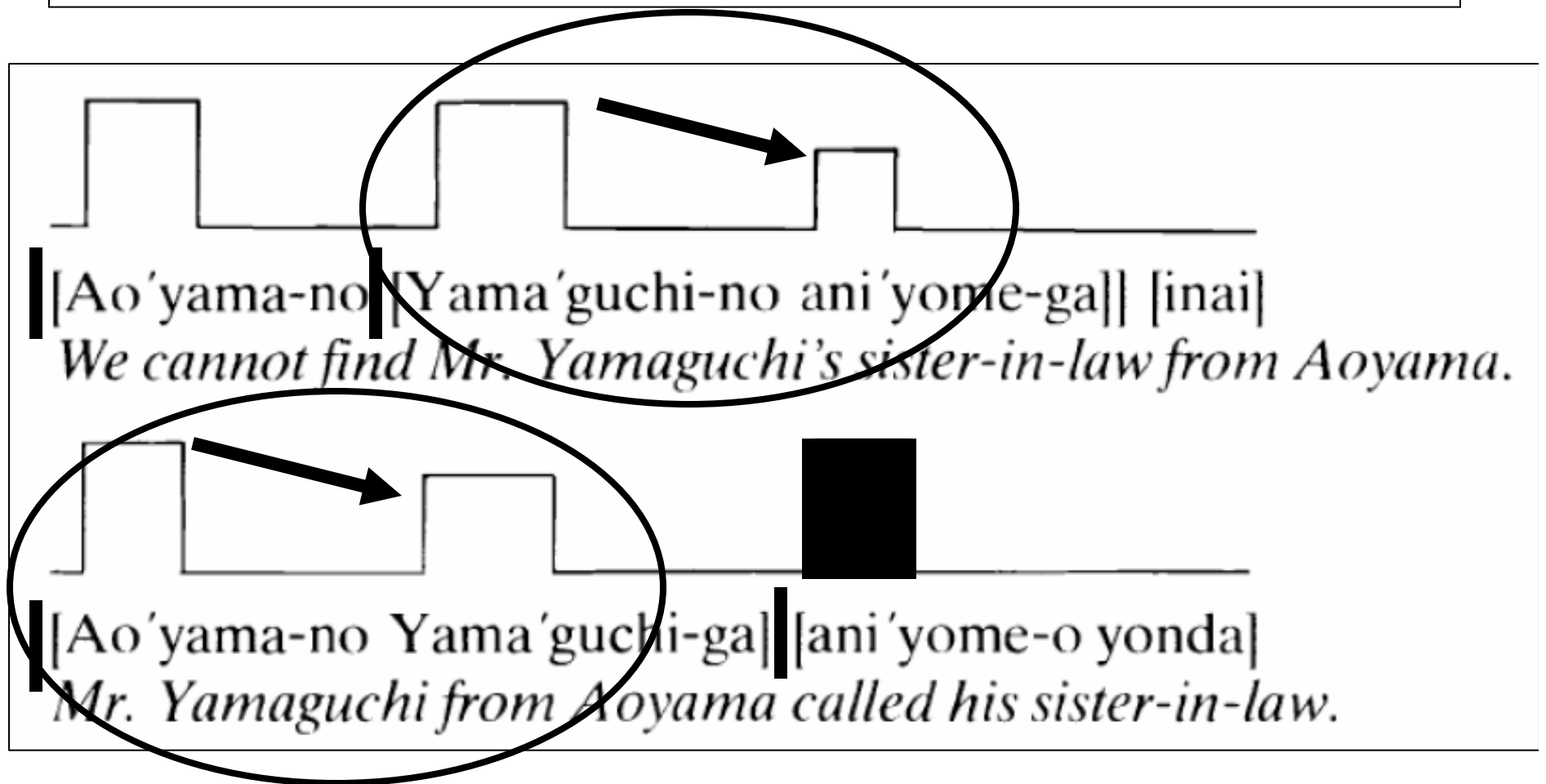

From Selkirk and Tateishi 1991

The domain arguments

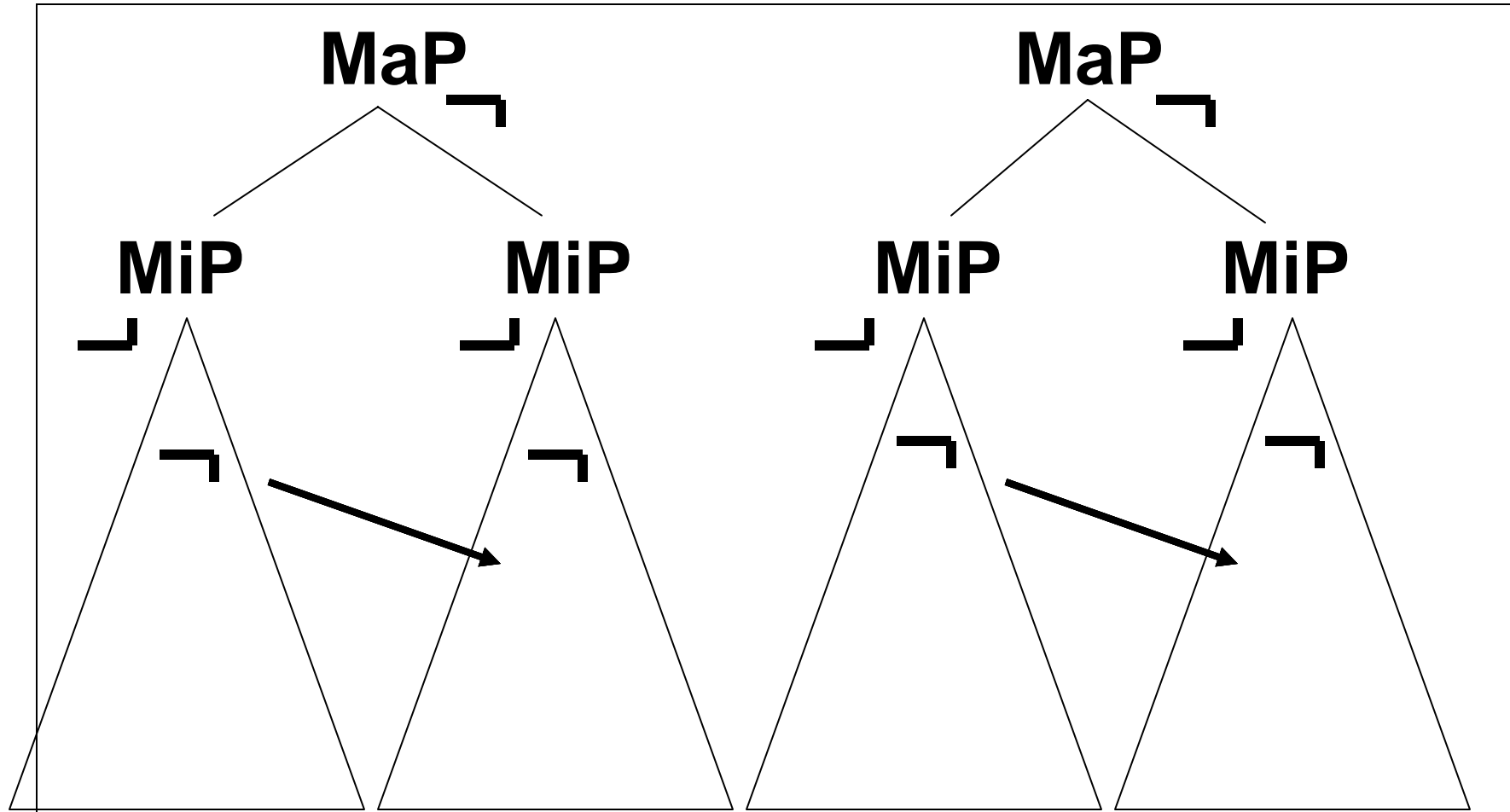

Questions

- How solid are the domain arguments?
- Are they sufficient grounds to motivate distinct categories?
- What would go wrong if both MaP and MiP are simply φ 's?

One- φ model

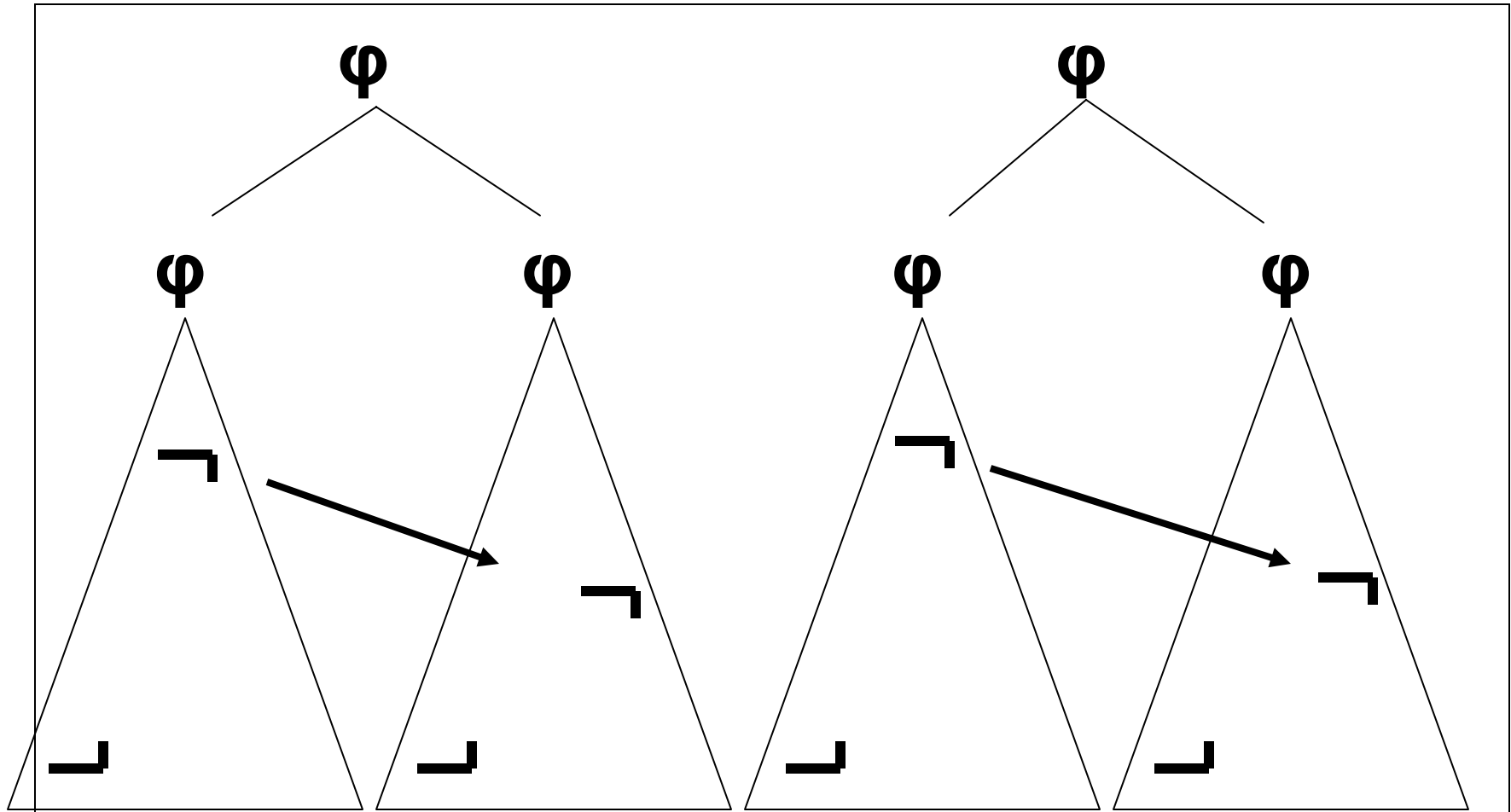

One- ϕ model

- Could the One- ϕ model possibly work?
- Surprising finding: It actually works without any problems.
- It turns out that there is no reason to distinguish between different kinds of phrases, MaP and MiP, as far as initial lowering and downstep are concerned.

No need to limit downstep to MaP

- A MiP contains maximally one accent;
- downstep requires two accents and cannot have any effect **within** MiP;
- it can apply vacuously to MiP;
- there is no reason to limit downstep to MaP.

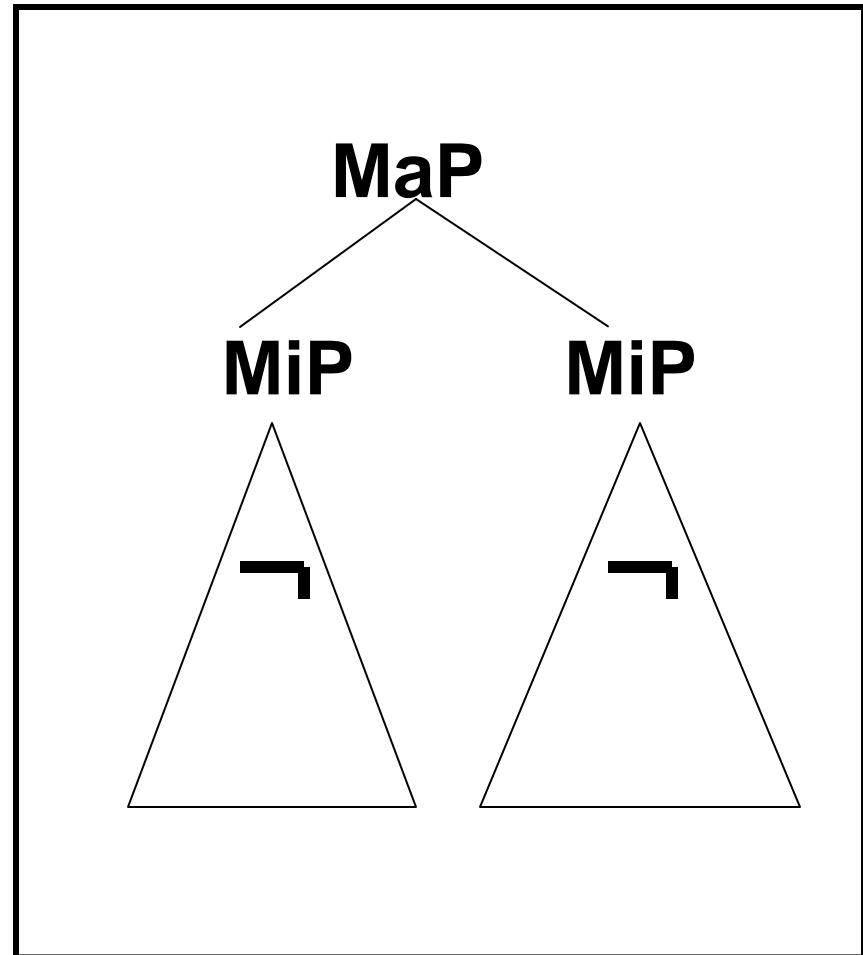

Downstep in all φ

\therefore Downstep applies to
EVERY φ .

(Here, vacuously to
the lower φ 's)

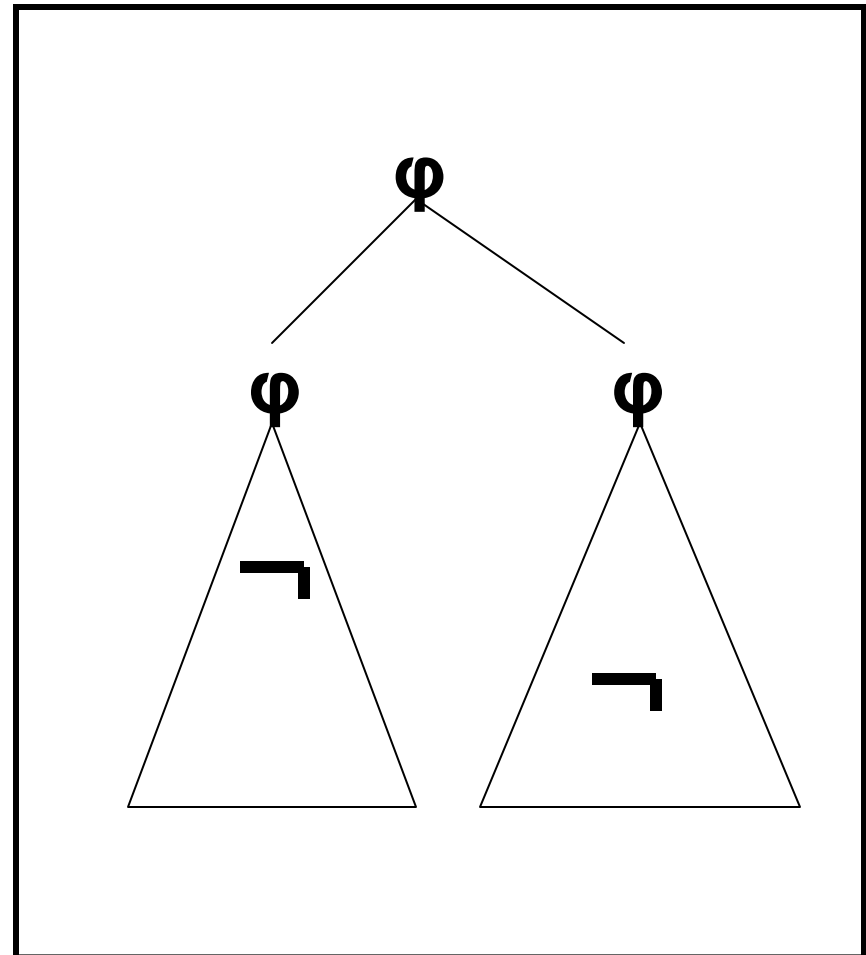

No need to limit lowering to MiP

- Initial Lowering is found not only
- **MiP**-initially,
- but also **MaP**-initially.
- The degree of initial lowering is even more extreme at MaP edges (Selkirk, Shinya, and Sugahara 2003).

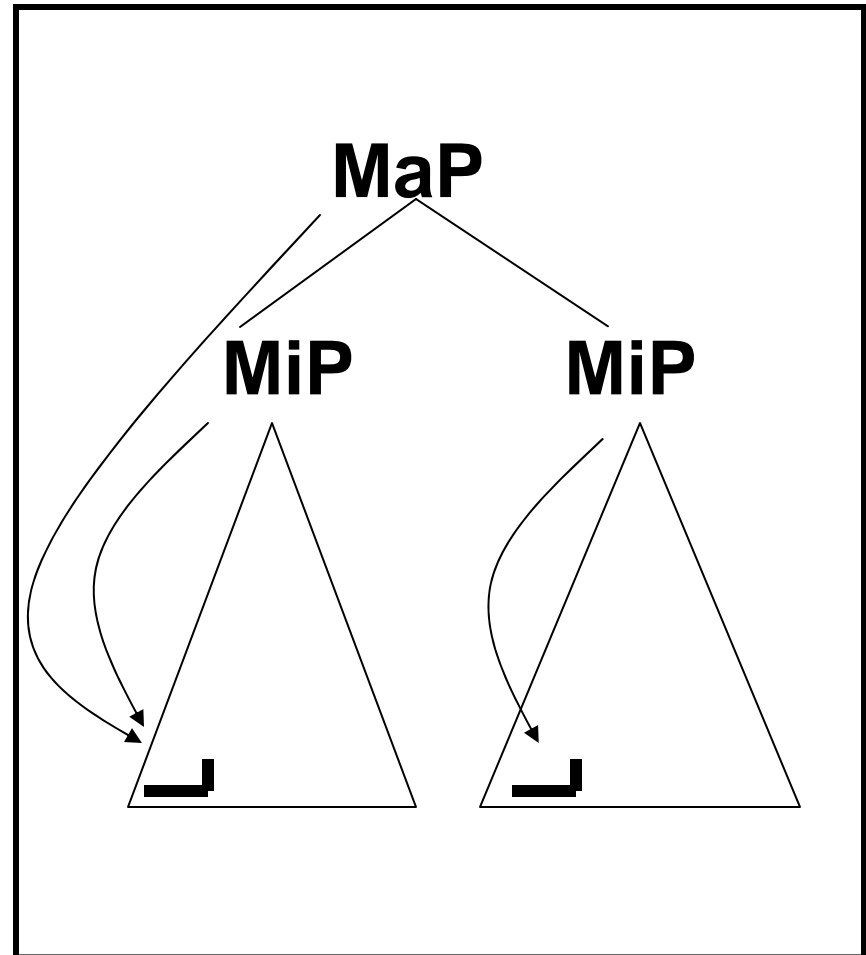

Lowering in all φ

\therefore Lowering applies to
EVERY φ .

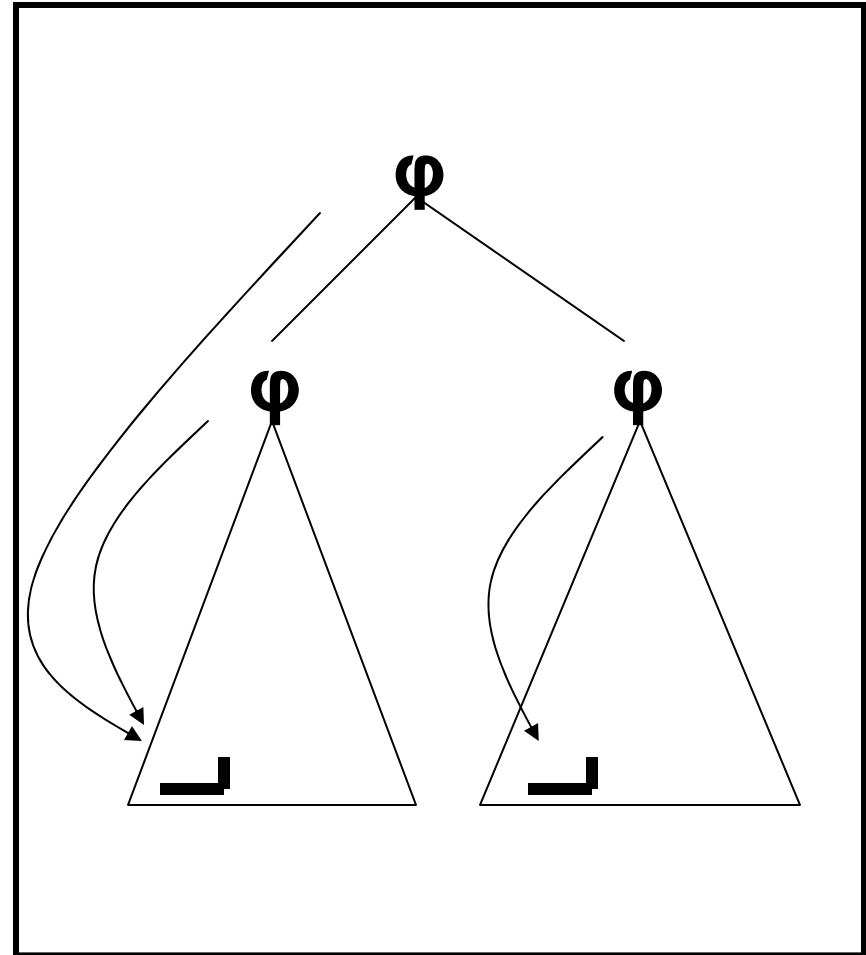

Downstep and initial lowering in the one- ϕ model

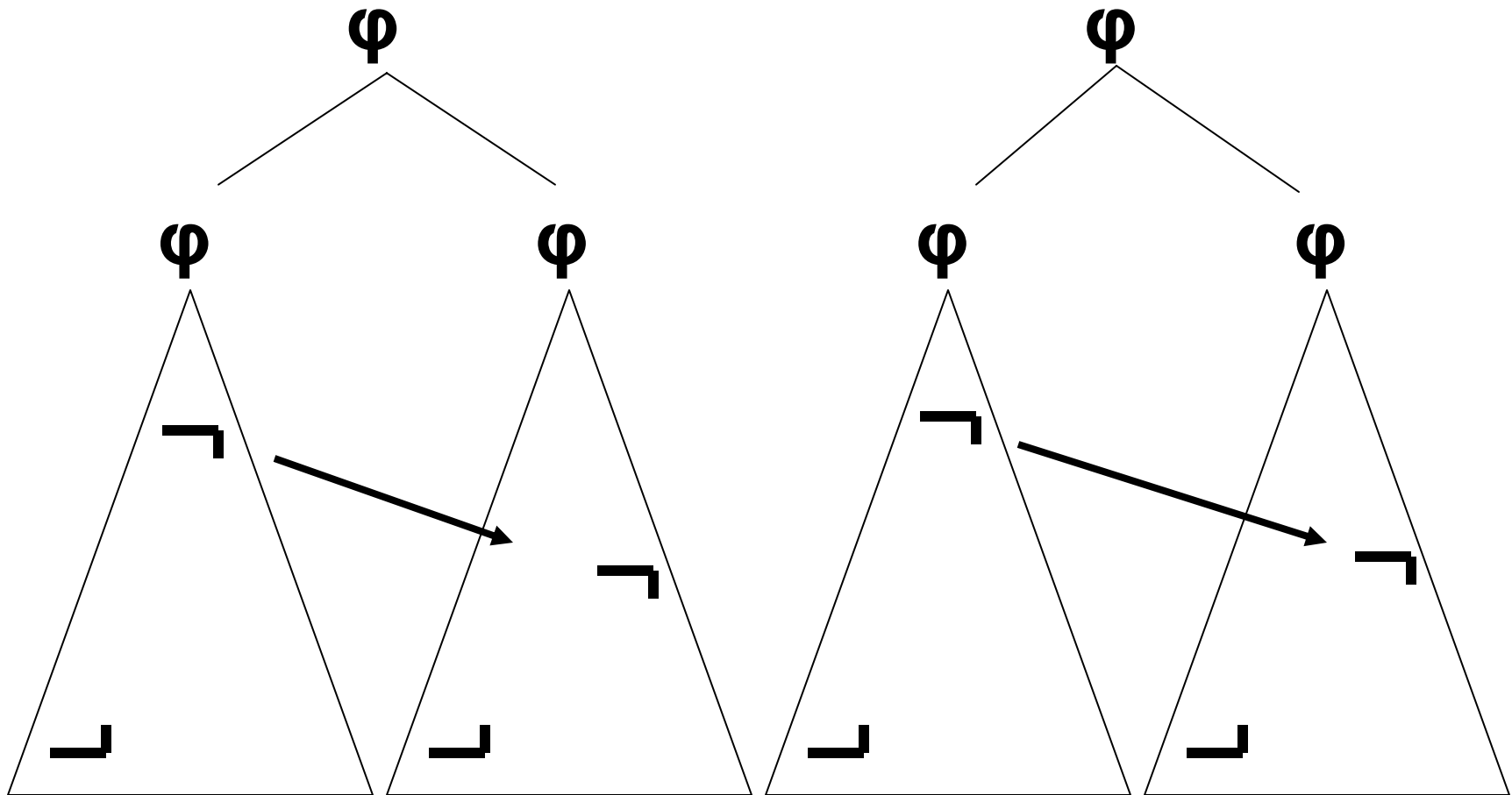

Trimming the hierarchy

- Immediate conclusion:
 - Initial lowering applies to all phrases (i.e., not just to MiP).
 - Downstep applies to all phrases (i.e., not just to MaP).
- More interesting conclusion:
 - Let there be no more MaPs and MiPs. Let there be only φ (“phrase”).

Maximal and minimal projections of φ

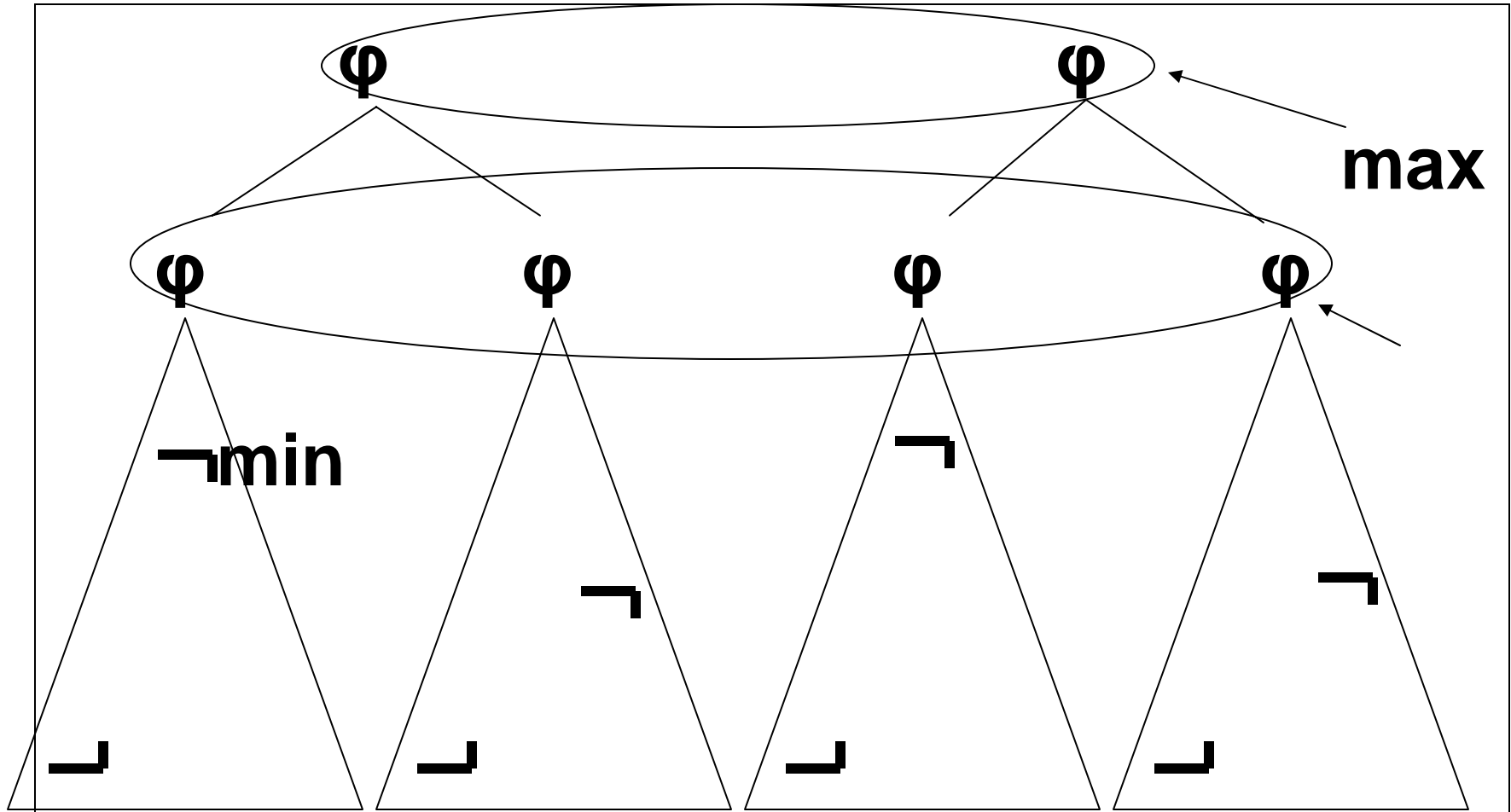

MiP/MaP vs. maximal- φ /minimal- φ

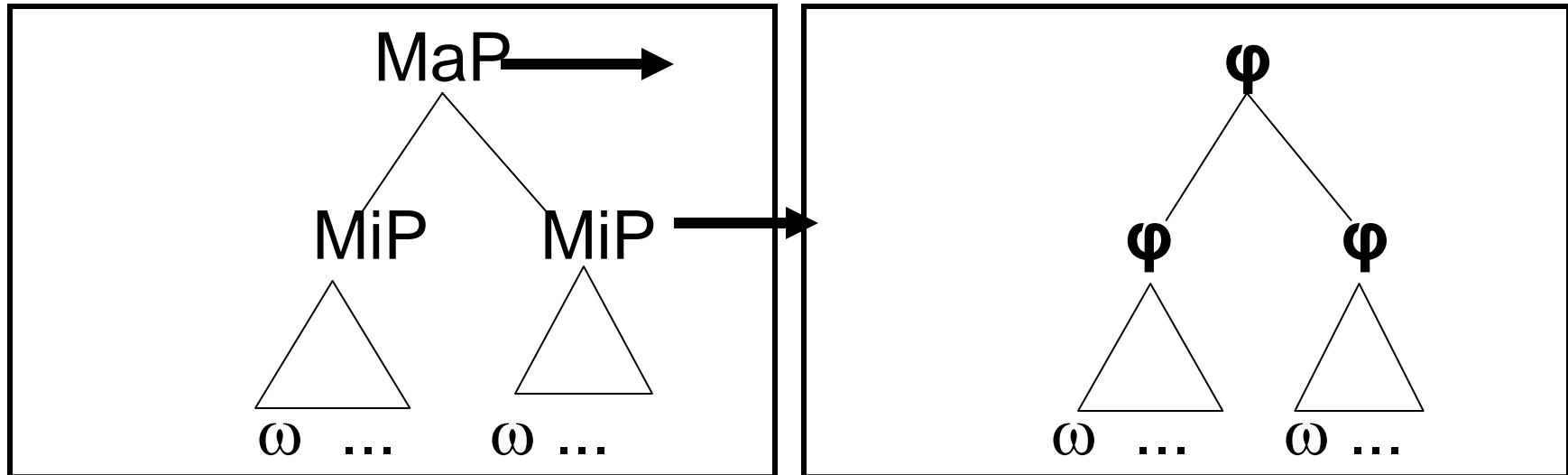

- In specific instantiations,
- MaP often corresponds to maximal φ ,
MiP to minimal φ .

MiP/MaP vs. maximal- ϕ /minimal- ϕ

- Does this mean that we are recreating MaP and MiP with new names?
- No, the two theories are not notational variants.
- There are significant differences between the two,
- and the evidence favors the single category approach.

MiP-MaP approach provides too much structure

MiP and MaP can appear nested if the Recursivity constraint is low-ranking.

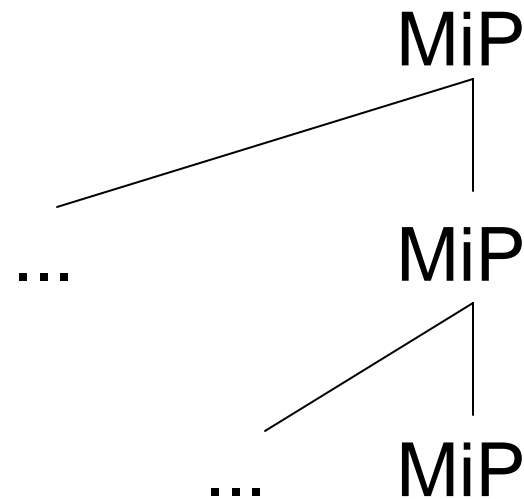
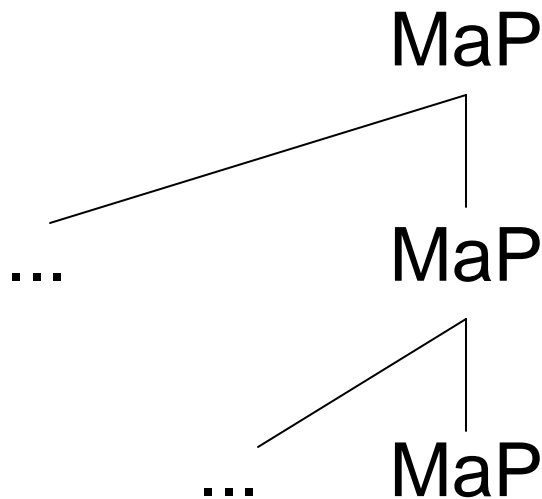

Inherent restrictiveness of the φ -only model

No such possibility for maximal and minimal φ .

There can only be **one maximal** and **one minimal** instantiation in every projection.

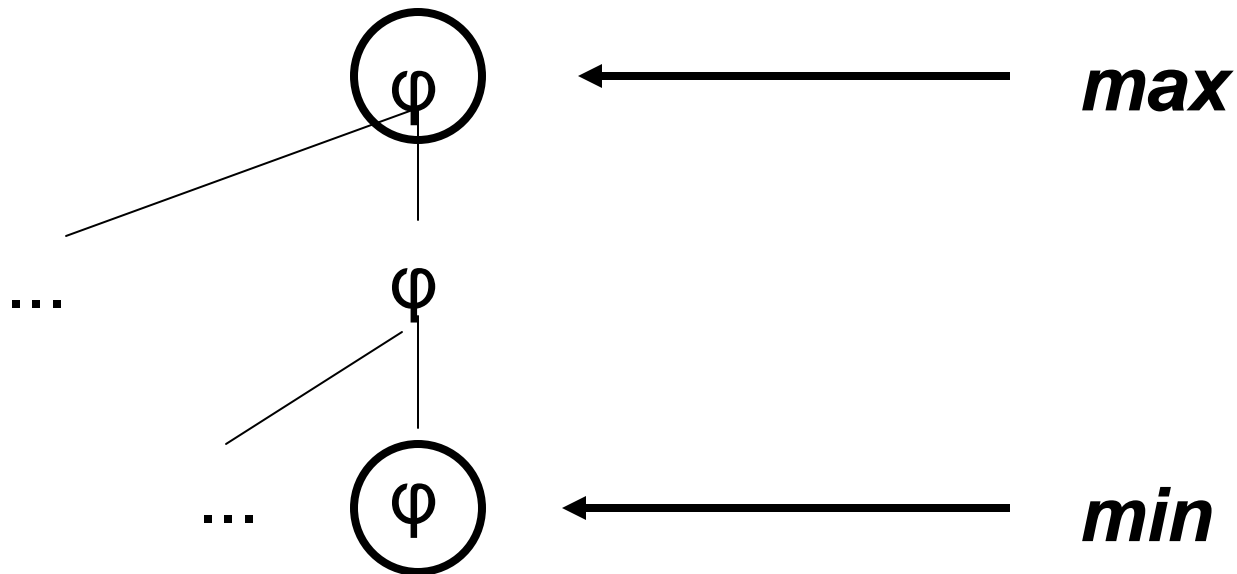

Nested MaP's disallowed in English

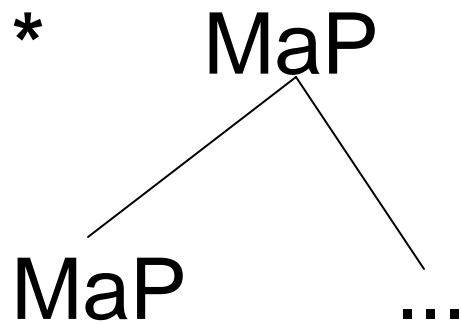

- Such recursive MaP structures need to be ruled out by specifically assuming high ranking NonRecursivity-MaP (Selkirk 2000: 25).

Nested MaP's disallowed in English

- If “MaP” \approx maximal φ , this follows automatically without invoking other constraints or ranking.
- There can be no such thing as a “recursive maximal φ .”

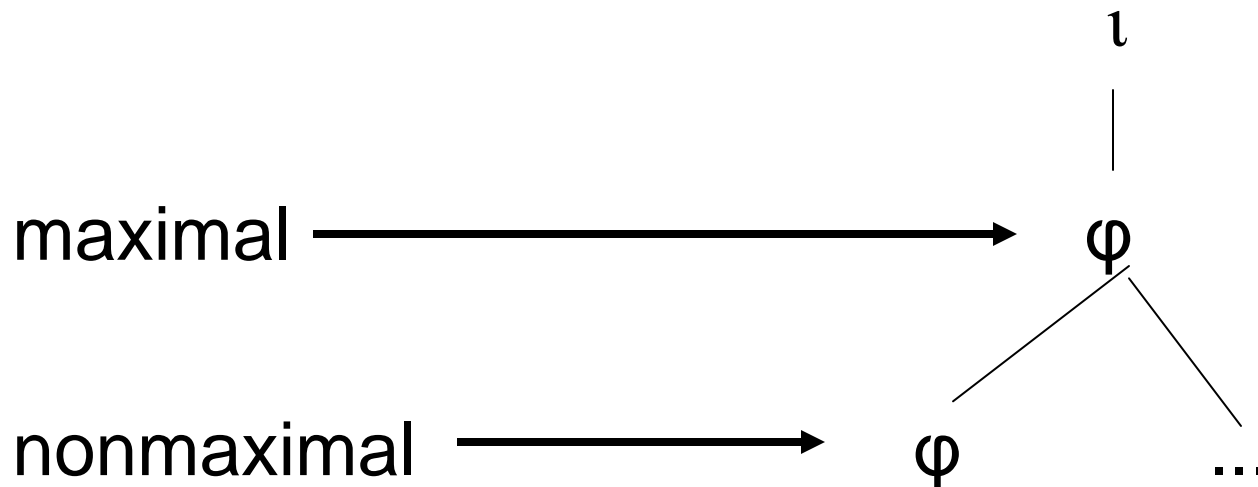

MiP-MaP approach provides too little structure

- Kubozono (1988, 1989):
Evidence that the standard MiP-MaP approach does not provide enough structure to represent the ways downstep plays out in Japanese.
- Kubozono's proposal: A sequence of four accented MiPs is restructured as a binary MiP-MiP sequence resulting in a recursive (branching) MiP structure.

Recursive MiP in Japanese?

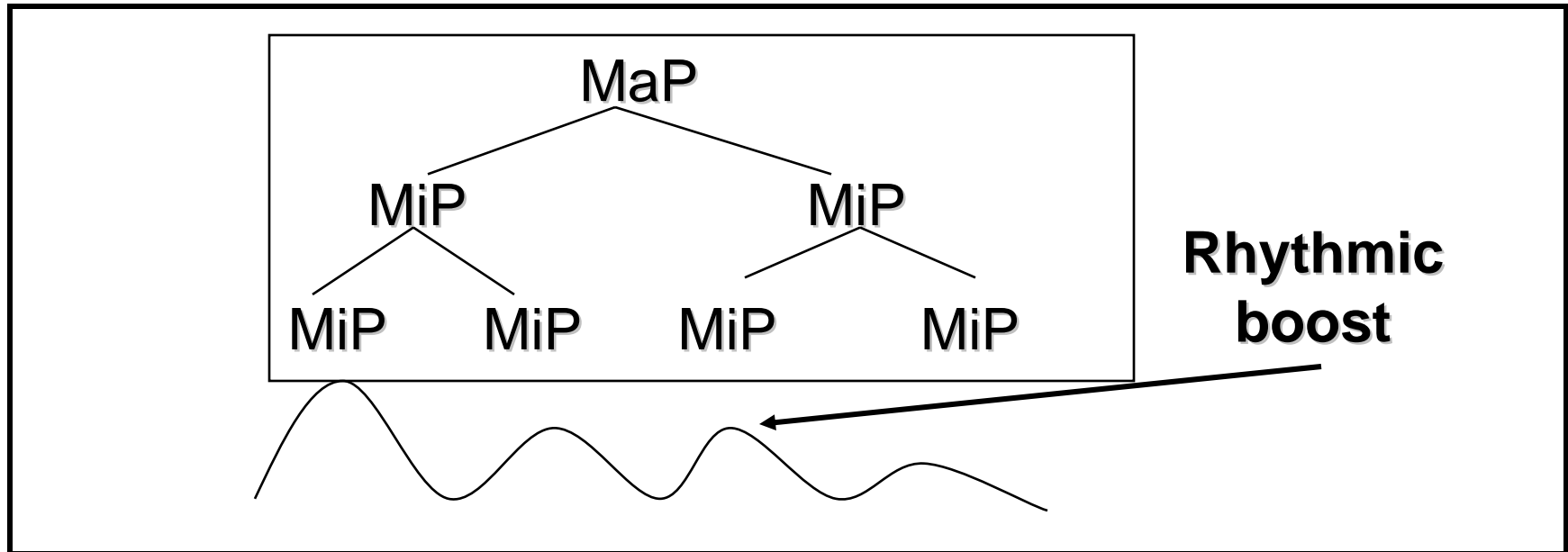

[[[náoko-no][áni-no]] [[aói] [erímaki]]]

‘(I saw) Naoko’s brother’s blue muffler’

A problem for recursive MiP

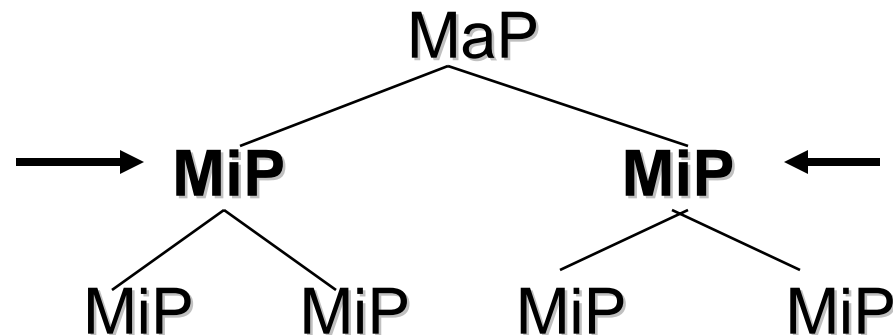

- The higher MiPs contain two accents, one from each of the subordinate MiPs.
- **PROBLEM:** This violates the one-accent-requirement on MiP.

No problem for φ -only model

- In the **φ -only model**, the issue does not even arise:
- The one-accnt requirement holds of minimal φ .
- The intermediate branching φ s are non-minimal,
- hence the requirement does not apply.

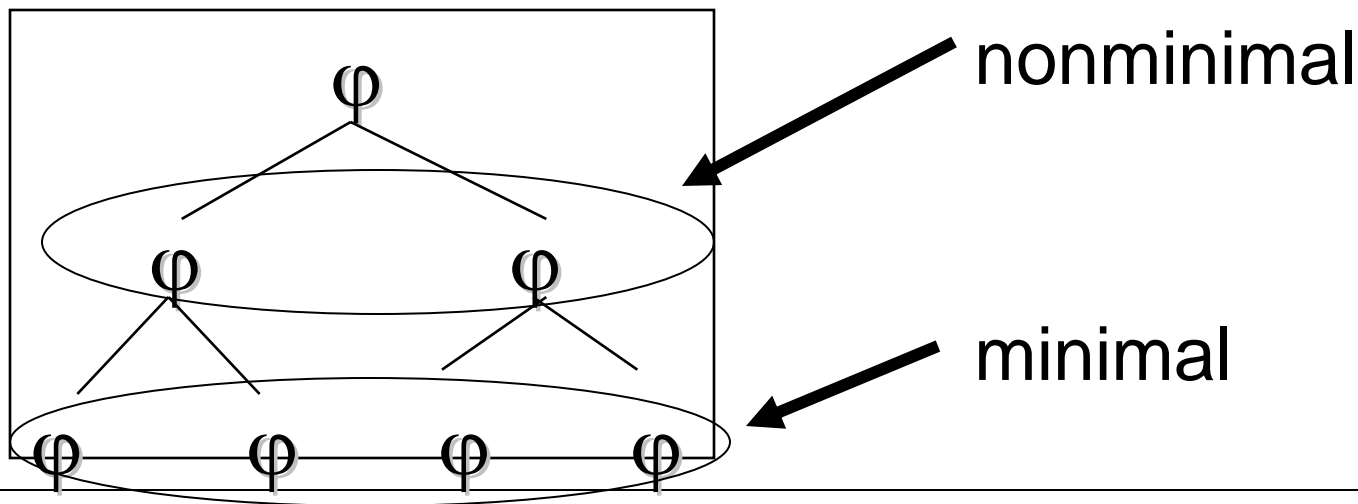

Focus and MaP domains

- Kubozono 2005, Kubozono, Kitagawa, Yoshida (WPSI 3):
- Focus does not block downstep: no pitch reset, i.e., no new MaP.
- Possibility: Prosodic structure with higher inclusive φ , and φ -recursion (triggered by the Focus element).
- Prediction: Downstep in any φ .
- No need to posit another prosodic category.

Reponse of MiP-MaP theory: add more categories

- In order to account for rhythmic boost, Shinya, Selkirk, and Kawahara 2004 introduce a new category:
- **SMiP** (“Superordinate Minor Phrase”),
- located between MiP and MaP.

Reponse of MiP-MaP theory: add more categories

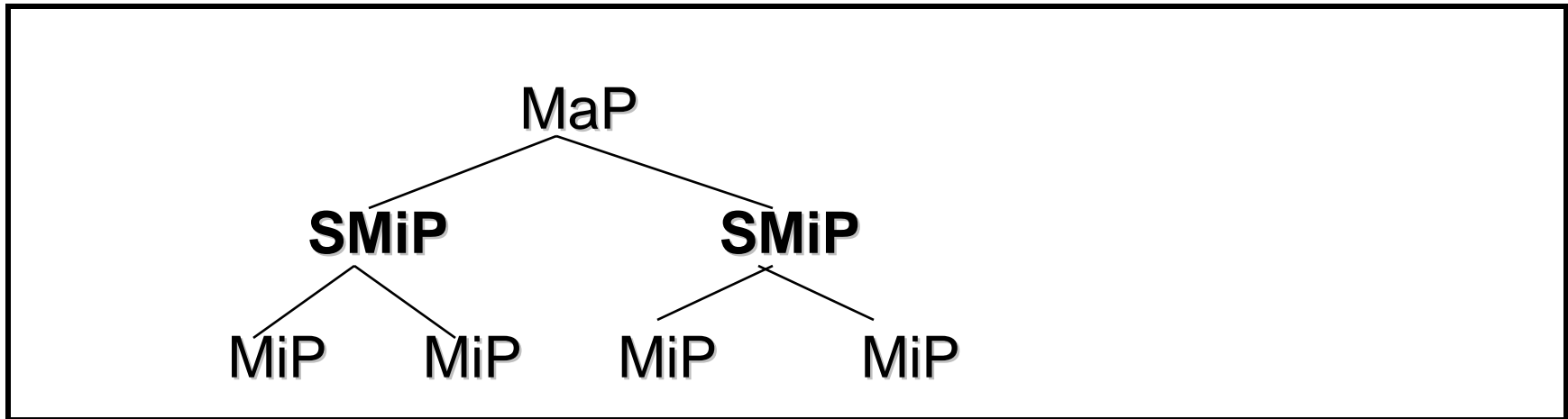

- SMiP = “Superordinate Minor Phrase”
- The one-accent requirement is assumed to hold only of MiP, not of SMiP.

Reponse of MiP-MaP theory: add more categories

- A similar response might be given to account for the focus-downstep facts:
- Either use the MaP-SMiP-MiP distinction, or introduce still another category—
- **SMaP** (“Subordinate Major Phrase”)

Comparison

- **MiP-MaP approach:**
- New intermediate category necessary

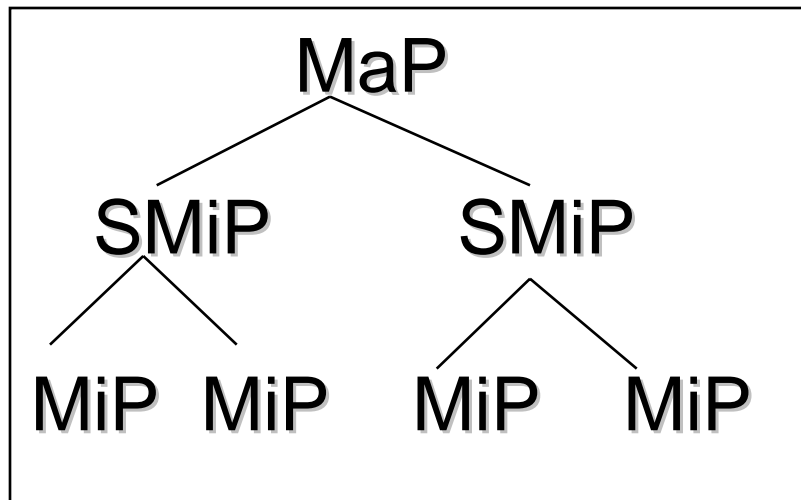

- **φ -only approach**
- No new assumptions necessary

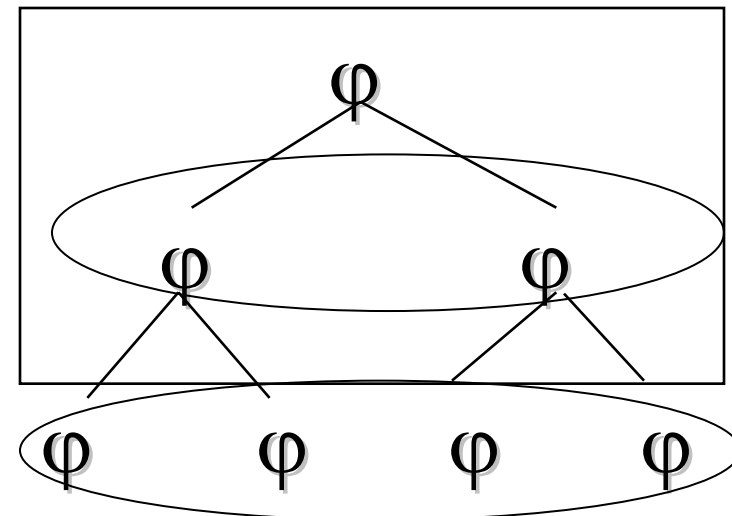

Labels as a liability

- What comes for free in φ -only theory requires a further elaboration of the labeled hierarchy in MiP-MaP theory.
- This further weakens the prospects for a cross-linguistically uniform hierarchy.

Initial Lowering

- **MiP-MaP approach:**
- Lowering occurs MiP-initially.
- **φ -only approach:**
- Lowering occurs at the beginning of EVERY phrase φ .

Initial Lowering

- The two theories make different predictions when MaP does *not* begin with MiP:

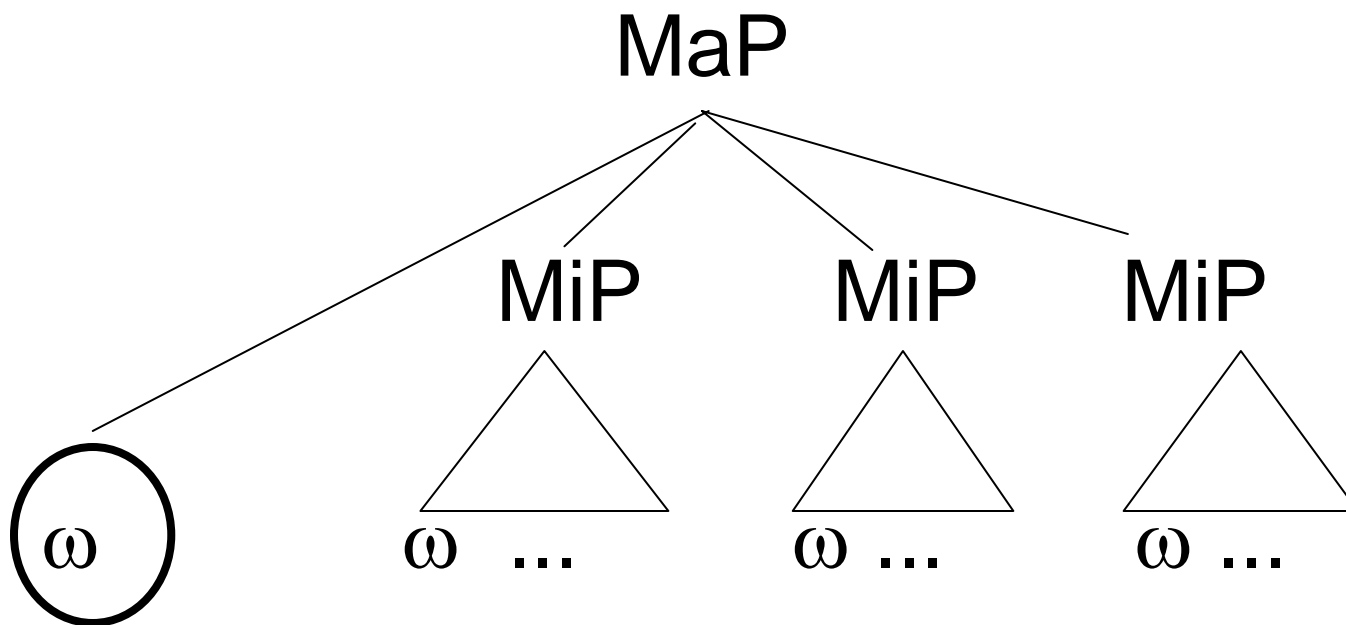

Initial Lowering predicted?

MiP-MaP:

No, since *not* MiP-initial

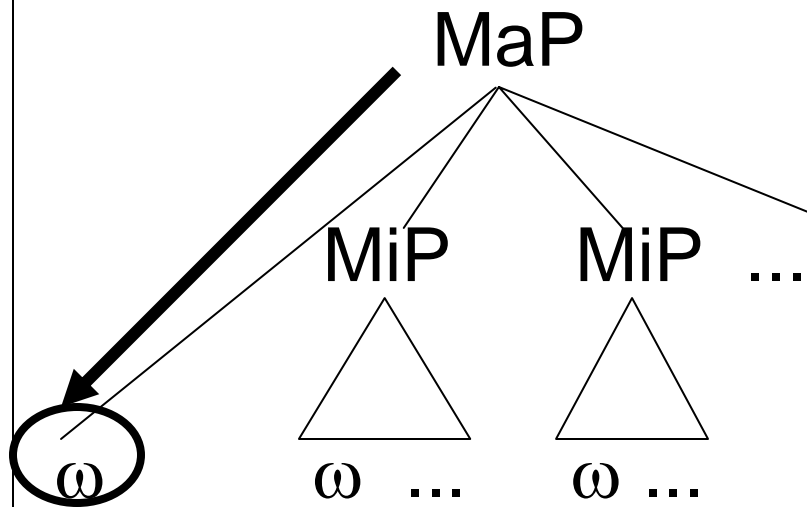

☹ Incorrect prediction

φ -only:

Yes, since φ -initial

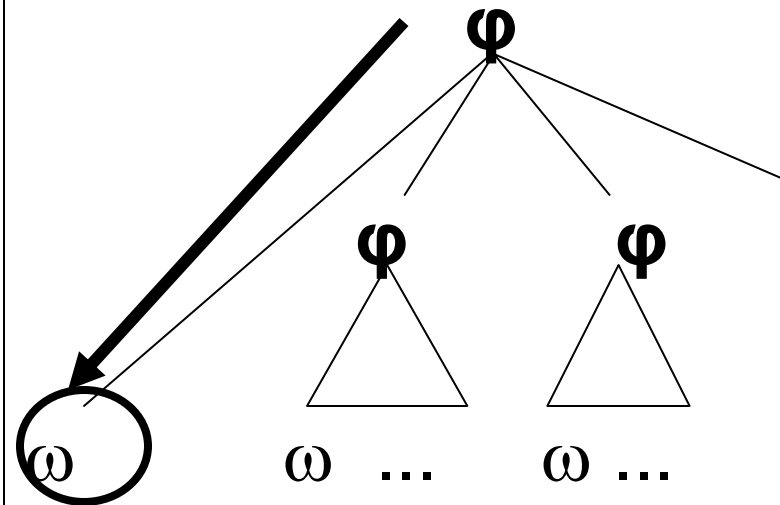

☺ Correct prediction

MaP-initial Lowering

- The degree of initial lowering is even more extreme at MaP edges (Selkirk, Shinya, and Sugahara 2003).
- This is a puzzling fact for the view that initial lowering is a MiP-exclusive property.

MaP-initial Lowering

- The MiP-MaP approach must stipulate that every MaP begins with a MiP.

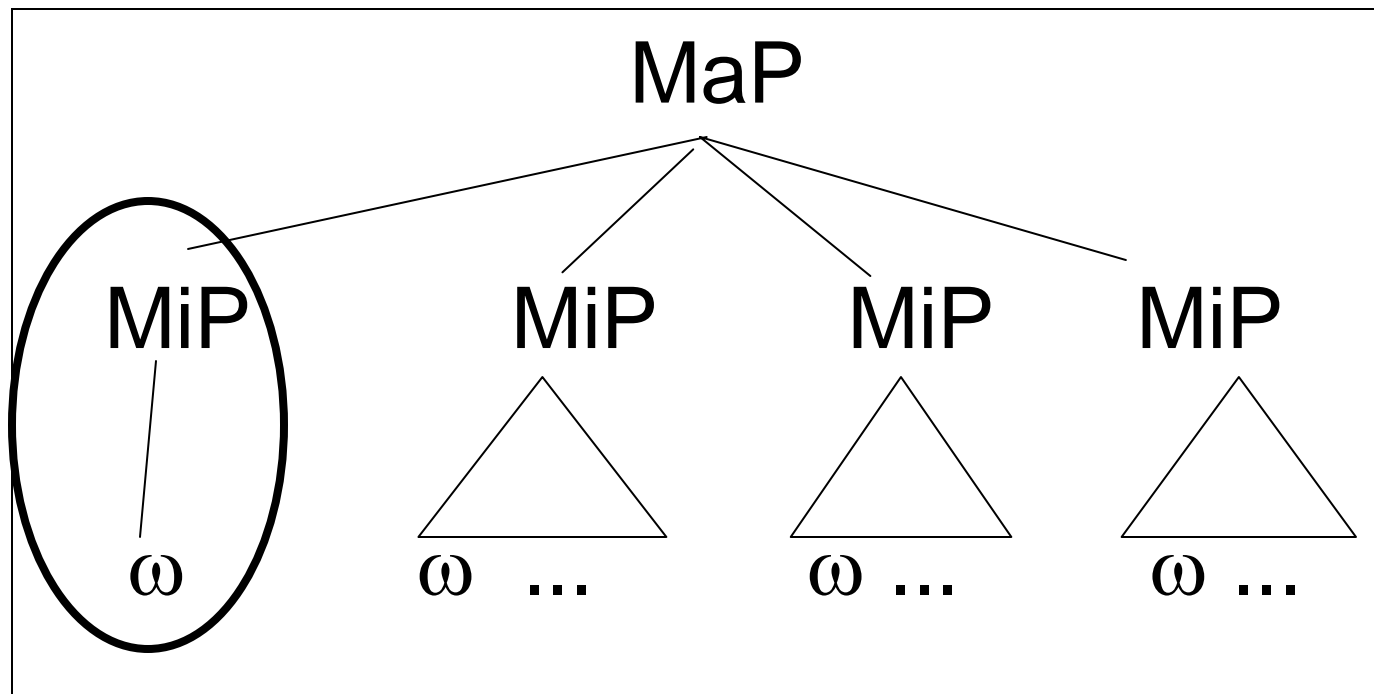

Initial Lowering

- **MiP-Map approach:**
- **ϕ -only approach:**
- Extra MiP at MaP edges necessary
- No extra structure necessary.
- Strict Layering must be enforced in this particular configuration.
- No extra assumptions necessary.

Degree of initial lowering

- What accounts for the different degrees of initial lowering?
- **φ -only approach**: Lowering occurs at the beginning of all φ , and more strongly at the beginning of a maximal φ .
- **MiP-MaP approach**: Another separate stipulation that MaP edges have more extreme lowering.

Summary of MiP/MaP problems

- (i) Domain arguments (downstep and initial lowering) to distinguish MiP and MaP do not go through.
- (ii) Further increase in categories, such as S(uperordinate)MiP.
- (iii) Stipulated Nonrecursivity of MaP.
- (iv) Stipulated left-alignment of MaP to MiP.

Case Study 3: Adjunction in English

- Further evidence for singling out the maximal ω among the ω -projections:
- ***r-sandhi*** in varieties of nonrhotic English (NRE), where [r] has been lost in syllable codas (*I paak my caa in Haavaad Yaad*).

Nonrhotic dialects

- r-loss word-finally (actually, σ -finally)

| underlying r | no underlying r |
|---------------------|------------------------|
| better/ | comma |
| star/ | law |
| soar/ | withdraw |
| star/ | Kafka |

R-sandhi

- Most well-known as a feature of British RP ("Received Pronunciation").
- Also found in other nonrhotic variants, as spoken in New Zealand, Eastern Massachusetts, and the Deep South of the U.S.

R-sandhi

| | underlying (linking) r | epenthetic (intrusive) r |
|--|---------------------------|-----------------------------|
| at word junction | bette-r-off | comma-r-in |
| | sta-r-is | law-r-of |
| word- internal junction (level 2) | soa-r-ing | withdraw-r-al |
| | sta-rr-y | Kafka-r-esque |

- after the non-high vowels [ə, ɔ:, ɑ:]

R-sandhi is productive

- Intrusive r in loanwords:
the Stella-r-Artois event
- NRE speakers' pronunciations of foreign languages:
ich habe-r-eine Reservierung (German)
hosanna-r-in excelsis (Latin)
(Wells 1982, McMahon 2000)

R-sandhi is widespread

- For example, a process virtually identical to the one in NRE exists in Bavarian German, with both linking and intrusive r.

wia-r-i gsagd hab

wie ich gesagt habe

'as I said'

kema-r-is

gekommen ist

'has come'

(Examples after Merkle 1975:30-33; Standard German versions added for comparison.)

Bavarian German

Mia kena-r-awa-r-aa-r-an andasmbi kema.

Wir können aber auch ein andersmal kommen.

'But we can also come another time.'

The function word gap

- In most dialects, intrusive *r* cannot appear at the juncture between a function word and a following word (McCarthy 1993).

*Fnc-*r*-Lex (*I wanna-*r*-eat)

*Fnc-*r*-Fnc (*add to-*r*-(h)is troubles)

Cf. Lex-*r*-Lex (Let Wanda-*r*-eat)

Lex-*r*-Fnc (the law-*r*-of the land)

The function word gap

didja eat?

* didja-r-eat?

I wanna eat

*I wanna-r-eat

he went to eat

*he went to-r-eat

the apples

*the-r-apples

The function word gap

Let Wanda $\widehat{\sigma}$ [reat]

*Let Wanda σ [eat]

*I'm gonna $\widehat{\sigma}$ [reat]

I'm gonna σ [eat]

Proclitic status

- Such function words in English are not prosodic words by themselves, but rather proclitic:

[gonna_{fnc}] [eat_ω]

* [gonna_{fnc}] [reat_ω]

[supposta_{fnc}] [add_ω]

* [supposta_{fnc}] [radd_ω]

Prosodic adjunction

- Function words in English form adjunction structures with following prosodic words:

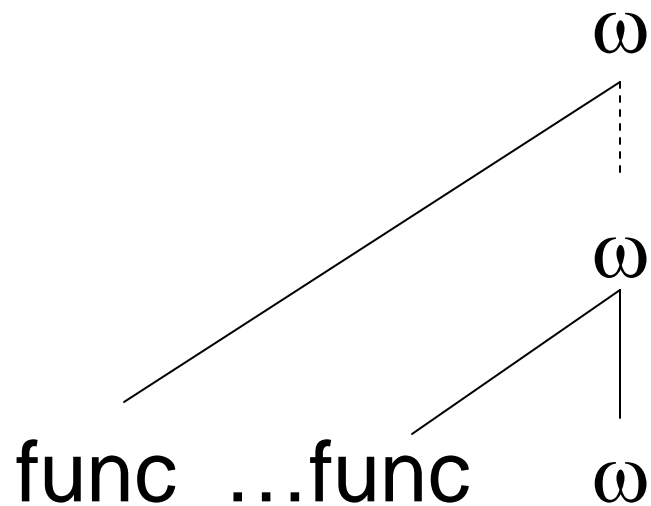

Prosodic adjunction

Reminder:

κ_{\max} =def κ not dominated by κ

κ_{\min} =def κ not dominating κ

For words,

- the resulting maximal projection is referred to as ω_{\max} ("maximal prosodic word"),
- its innermost ω -subconstituent as ω_{\min} ("minimal prosodic word").

Consequence of adjunction

Eat does not have the same prosodic status

- in *lex+lex*:
Let Wanda $\widehat{\sigma}$ [reat]
- and *fnc+lex*:
I'm gonna σ [eat]

A structural difference

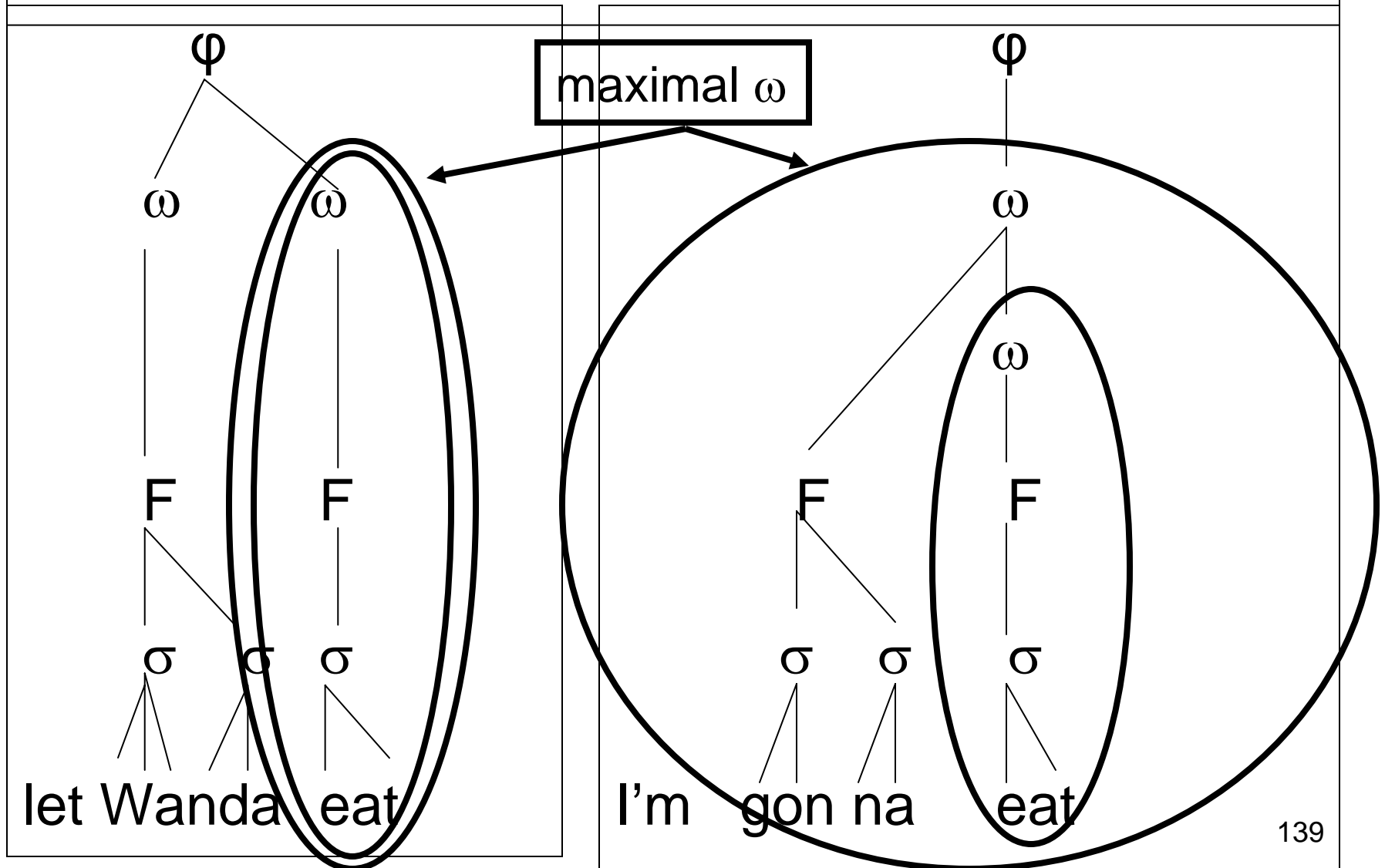

A structural difference

Let Wanda $\widehat{\sigma}[\text{reat}]$ ← maximal ω

I'm gonna $\sigma[\text{eat}]$ ← subpart of a maximal ω

Consequences for *r*-insertion

| | | | |
|-----|--------------|-------------------------------|--------------|
| | | <p>r-inserting candidates</p> | |
| Let | Wand[ə r]eat | I'm | gonn[ə r]eat |

| | | | |
|-----|--------------------------|-----|-------------|
| | <p>hiatal candidates</p> | | |
| Let | Wand[ə] eat | I'm | gonn[ə] eat |

Analysis

ONSET(ω_{\max})

* [ω_{\max} V

Special version of Onset-constraint for prominent positions (maximal projections of ω)

DEP-init(ω)

Positional faithfulness: special version of DEP-constraint ruling out insertion of a root node. (Root node is filled by spreading from preceding vowel, hence no phrase-initial epenthetic *r*.)

Any root node of the output in ω -initial position has an input correspondent.

Ranking

Onset(ω_{\max})

|

Dep-init(ω)

|

Onset

|

Dep

(Let) Wanda eat

- Onset(ω_{\max}) » Dep-init(ω)

| <i>... Wanda eat</i> | Ons (ω_{\max}) | Dep -init(ω) | Ons | Dep |
|---|----------------------------|--------------------------|-----|-----|
| ▶ [<i>Wanda</i>] [<i>reat</i>] ω_{\max} ω_{\max} | | * | | * |
| [<i>Wanda</i>] [<i>eat</i>] ω_{\max} ω_{\max} | *! | | * | |

(l) wanna eat

- Dep-init(ω) » Onset

| <i>... wanna eat</i> | Ons (ω_{\max}) | Dep -init(ω) | Ons | Dep |
|--|----------------------------|--------------------------|-----|-----|
| ω_{\max} F ω [[wanna] [reat]] | | *! | | * |
| ω_{\max} F ω ► [[wanna] [eat]] | | | * | |

Emergence of Onset

- Epenthetic **r** is excluded after function words because of high-ranking Dep-init(ω). The other kind of r-sandhi, underlying **r**, is not:

| <i>for eating</i> | Ons (ω_{\max}) | Dep -init(ω) | Ons | Dep |
|--|----------------------------|--------------------------|-----|-----|
| ▶ [[<i>fo</i>] [<i>r</i> eating]] ω_{\max} σ ω | | | | |
| [[<i>fo</i>] [<i>eating</i>]] ω_{\max} σ ω | | | *! | |

Side issue: Why insert *r*?

- R-insertion is a kind of diphthongization of the preceding vowel.
- Kahn (1976:69-70), Broadbent (1991), Gnanadesikan (1997:159-162), Bakovic 1999, Uffmann 2003, 2005, Rawlins 2004.

Saw [r]Ed

- DEP-INIT(ω) is therefore actually DEP-ROOTNODE-INIT(ω),
- with the root node filled by spreading from preceding non-high central/back vowels.

| <i>saw Ed</i> | Ons (ω_{\max}) | Dep-root -init(ω) |
|---|----------------------------|-------------------------------|
| <p>▶ [sɔ] [<u>r</u>ɛd]</p> <p>Place</p> | | * |
| <p>[sɔ] [ɛd]</p> <p>ω_{\max} ω_{\max}</p> | *! | |

*[r]Ed

- High-ranking DEP-PLACE prevents post-pausal epenthesis.

| <i>Ed</i> | Dep-Place | Ons (ω_{\max}) | Dep-root-init(ω) |
|----------------------------|-----------|-------------------------|---------------------------|
| [rɛd] ω_{\max} | *! | | * |
| ▶ [ɛd] ω_{\max} | | * | |

R-insertion in other dialects

- Cockney English and some other dialects (e.g., Norwich) spoken in the British Isles show a more extensive process of r-insertion:
- more vowels reduced to schwa, the main sponsor of the inserted segment;
- less restrictive prosodic context: no function word gap.

Cockney

| | |
|-------------------|-----------------------------------|
| <i>tomato</i> | tomat[ə r]and cucumber production |
| <i>window</i> | pull the wind[ə r]up |
| <i>you how</i> | I'll tell y[ə ræ:] |
| <i>you a</i> | Give [jə rə] job |
| <i>not a hope</i> | not [ə rəʊp] |

- Sources: McMahon 2000, Sivertsen 1960, Trudgill 1974, Wells 1982

Norwich

| | |
|-----------------|----------------------|
| <i>to it</i> | [tə r]it |
| <i>by a</i> | run over [bə rə] bus |
| <i>of old</i> | lot [ə r]old |
| <i>to eat</i> | out [tə r]eat |
| <i>to eight</i> | quarter [tə r]eight |

- Note insertion after function words (*to-r-eat*)

Analysis

- Standard non-rhotic:

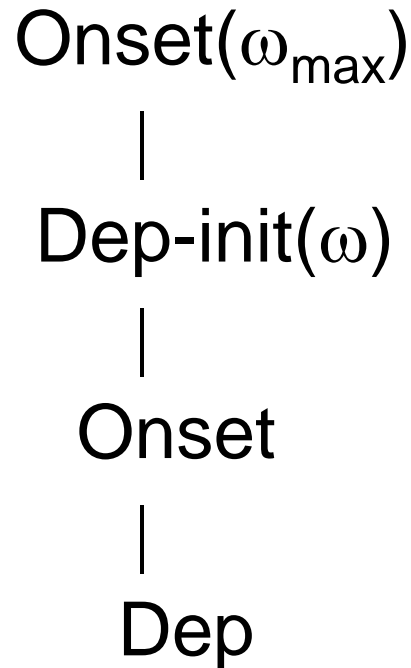

- Norwich, etc.:

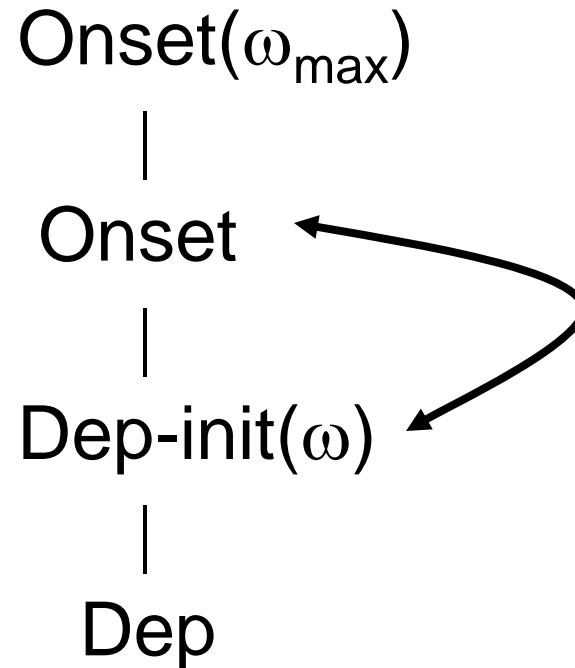

Norwich *to-r-eat*

| <i>to eat</i> | Ons (ω_{\max}) | Ons | Dep -init(ω) | Dep |
|---|----------------------------|-----|--------------------------|-----|
| ▶ [[<i>tə</i>] [<i>rit</i>]] ω_{\max} σ ω | | | * | * |
| [[<i>tə</i>] [<i>it</i>]] ω_{\max} σ ω | | *! | | |

Summary

- We have proposed a minimal prosodic ontology at the phrase level:
- Only ω and φ are distinct categories
- Adjunction structures play a large role
- Relational notions, such as “maximal/minimal projection of category α ”, are essential for the formulation of constraints.

“strictly layered”

Consequences

| | Layering fulfilled | Layering violated |
|-----------------------|---|---|
| Recursivity fulfilled | <pre>graph TD; A[ω] --- B[F]; A --- C[F];</pre> | <pre>graph TD; A[ω] --- B[σ]; A --- C[F];</pre> |
| Recursivity violated | <pre>graph TD; A[ω] --- B[F]; A --- C[ω];</pre> | <pre>graph TD; A[ω] --- B[σ]; A --- C[ω];</pre> |

Layering and recursion

- Strictly layered structures with no recursion impose a fixed upper limit on the depth of prosodic structures.
- This limit is too tight.
- On the other hand, grammars impose limits on recursive structure:
 - In terms of number of recursions
 - Based on binarity
 - Based on phonetic length

Layering and recursion

- It is unclear whether layering is ever clearly violated at the phrase level, different from word-internal prosody.
- Cases where σ is demonstrably dominated by φ are hard to find (but see Selkirk 1996 for English, Hall 1999 for German).

Layering and recursion

- On the other hand, layering violations are common at the word-foot level due to non-exhaustive parsing (unfooted σ directly dominated by ω).
- See Hayes 1995, Ito and Mester 1992, Kager 1993, McCarthy & Prince 1993, Mester 1994, Prince & Smolensky 1993, and many other refs.

Layering and recursion

- The opposite holds for recursive structures:
- They are quite common for ω and higher constituents
- But recursive foot and syllable structures have rarely been proposed, and are not solidly motivated.

Summary of properties

Below the word level:

F, σ

- Recursivity violations rare
- Layering violations frequent

Word and higher levels:

ω , φ , ι

- Recursivity violations frequent
- Layering violations rare

Similar difference in binarity violations

- Binarity is usually observed below the word level:
- Ternary feet and trimoraic syllables are often ungrammatical.
- But at higher levels, ω , φ , ι , there is usually only a *tendency* towards binarity (as the unmarked option).

Why this systematic difference?

There are two different kinds of prosodic categories:

- Intrinsically defined categories
- Extrinsically defined categories

Two kinds of categories

Intrinsically defined categories:

- Word-internal prosodic units are largely governed by substantive constraints.
- These deal with syllable and foot shape and relate to sonority profile and rhythm.

Extrinsically defined categories:

- Higher-level units are largely governed by syntax-phonology mapping constraints (Alignment, Wrap, etc.).

Layering: phrasal vs. word-internal

- Word-internal violations of Layering are frequent—
- due to high-ranking substantive constraints.
- Violations of Layering above the word are rare—
- because such substantive constraints on form and rhythm are largely absent for extrinsically defined prosodic categories.

References

- Bakovic, Eric. 2000. Deletion, insertion, and symmetrical identity. *Harvard Working Papers in Linguistics* 7.
<http://roa.rutgers.edu/files/300-0299/roa-300-bakovic-2.pdf>
- Beckman, Mary, and Janet Pierrehumbert. 1986. Intonational structure in English and Japanese. *Phonology* 3:255–309.
- Broadbent, Judith. 1991. Linking and intrusive r in English. *UCLA Working Papers in Linguistics* 3:281–302.
- Féry, Caroline, and Hubert Truckenbrodt. 2005. Sisterhood and tonal scaling. *Studia Linguistica* 59:223–243.
- Gimson, A.C., and Alan Cruttenden. 2001. *Gimson's Pronunciation of English*. London: Arnold.

- Gnanadesikan, Amalia. 1997. *Phonology with Ternary Scales*. Department of Linguistics, UMass at Amherst: Doctoral dissertation.
- Goedemans, Rob. 1994. An optimality account of onset sensitivity in QI languages. Ms. <http://roa.rutgers.edu/files/26-0994/26-0994-GOEDEMANS-0-0.PDF>.
- Gussenhoven, Carlos. 1991. The English rhythm rule as an accent deletion rule. *Phonology* 8:1–35.
- Gussenhoven, Carlos. 2005. Procliticized phonological phrases in English: Evidence from rhythm. *Studia Linguistica* 59:174–193.
- Hall, T. Alan. 1999. Phonotactics and the prosodic structure of German function words. In *Studies on the Phonological Word*, eds. T. Alan Hall and Ursula Kleinhenz. Amsterdam, The Netherlands, and Philadelphia, USA: John Benjamins. 99–131.

- Haraguchi, Shosuke. 1977. *The Tone Pattern of Japanese: An Autosegmental Theory of Tonology*. Tokyo: Kaitakusha.
- Hayes, Bruce. 1989. The prosodic hierarchy in meter. In *Rhythm and Meter*, eds. Paul Kiparsky and G. Youmans, 201–260. Orlando: Academic Press.
- Hayes, Bruce. 1995. *Metrical Stress Theory: Principles and Case Studies*. Chicago: The University of Chicago Press.
- Hewitt, Mark. 1994. Deconstructing Foot Binarity in Koniag Alutiiq. Ms., Brandeis University, Waltham, MA.
<http://roa.rutgers.edu/view.php3?id=132>.
- Inkelas, Sharon. 1989. Prosodic Constituency in the Lexicon, Stanford University: Doctoral dissertation. Published 1990, Outstanding Dissertations in Linguistics Series, Garland Press, New York.

- Ito, Junko. 1990. Prosodic minimality in Japanese. In *CLS 26: Parasession on the Syllable in Phonetics and Phonology*, eds. K. Deaton, M. Noske and M. Ziolkowski. Chicago: Chicago Linguistic Society. 213–239.
- Ito, Junko, and Armin Mester. 2003(1992). Weak layering and word binarity. In *A New Century of Phonology and Phonological Theory. A Festschrift for Professor Shosuke Haraguchi on the Occasion of His Sixtieth Birthday*, eds. Takeru Honma, Masao Okazaki, Toshiyuki Tabata and Shin-ichi Tanaka. Tokyo: Kaitakusha. 26–65. Slightly revised version of 1992 LRC working paper.
- Ito, Junko, Yoshihisa Kitagawa, and Armin Mester. 1996. Prosodic faithfulness and correspondence: Evidence from a Japanese Argot. *Journal of East Asian Linguistics* 5:217–294.

- Ito, Junko, and Armin Mester. 1999. Realignment. In *Proceedings of the Utrecht Workshop on Prosodic Morphology*, eds. René Kager, Harry van der Hulst and W. Zonneveld. Cambridge: Cambridge University Press.
- Ito, Junko, and Armin Mester. 2003. *Japanese Morphophonemics: Markedness and Word Structure*. Linguistic Inquiry Monographs, 41. Cambridge, MA, and London, England: MIT Press.
- Kager, René. 1993. Alternatives to the iambic-trochaic law. *Natural Language and Linguistic Theory* 11:381–432.
- Kahn, Daniel. 1976. *Syllable-based Generalizations in English Phonology*. MIT: Doctoral dissertation. Published by Garland Press, New York, 1980.
- Kawahara, Shigeto, and Takahito Shinya. 2006. The intonation of gapping and coordination in Japanese: evidence for

Intonational Phrase and Utterance. Ms.: University of Massachusetts, Amherst.

Kozasa, Tomoko. 2000. Moraic tetrameter in Japanese poetry. In *Proceedings 2000: Selected Papers from the 4th College-wide Conference for Students in Languages, Linguistics and Literature*, eds. G. Sibley, N. Ochner and K. Russell. Honolulu, HI: National Foreign Language Resource Center. 9–19.

<http://www2.hawaii.edu/~kozasa/Meter.pdf>.

Kubozono, Haruo. 1988. *The Organization of Japanese Prosody*. University of Edinburgh: Doctoral dissertation.

Kubozono, Haruo. 1993. *The Organization of Japanese Prosody*. *Studies in Japanese Linguistics*. vol. 2. Tokyo: Kurosio Publishers.

Kubozono, Haruo. 2005. Focus and intonation in Japanese: Does focus trigger pitch reset? In *Interdisciplinary Studies on*

Information Structure. Working Papers of the SFB 632, eds. S. Ishihara, M. Schmitz and A. Schwarz. Potsdam: Universitätsverlag Potsdam.

Kubozono, Haruo, Junko Ito, and Armin Mester. 1997.

On'inkôzô-kara mita go-to ku-no kyôkai: fukugô-meishi akusento-no bunseki [The word/phrase boundary from the perspective of phonological structure: the analysis of nominal compound accent]. In *Bunpô-to onsei. Speech and Grammar*, ed. Spoken Language Research Group, 147–166. Tokyo: Kurosio Publications.

Ladd, D. Robert. 1986. Intonational phrasing: The case for recursive prosodic structure. *Phonology* 3:311–340.

Ladd, D. Robert. 1988. Declination "reset" and the hierarchical organization of utterances. *Journal of the Acoustical Society of America* 84:530–544.

- McCarthy, John J. 1991. Synchronic Rule Inversion. In Proceedings of the Annual Meeting of the Berkeley Linguistics Society, eds. L. Sutton, C. Johnson and R. Shields. 192–207.
- McCarthy, John J. 1993. A case of surface constraint violation. *Canadian Journal of Linguistics* 38:127–153.
- McCarthy, John J., and Alan S. Prince. 1993. Generalized Alignment. In Yearbook of Morphology, eds. Geert Booij and Jaap van Marle. 79–153.
- McCawley, James D. 1968. *The Phonological Component of a Grammar of Japanese*. The Hague, The Netherlands: Mouton.
- McCawley, James D. 1977. Accent in Japanese. In *Studies in Stress and Accent*, ed. Larry Hyman, 261–302. Los Angeles: USC.

- McCloskey, James. 1983. A VP in a VSO language. In *Order, Concord, and Constituency*, eds. G. Gazdar, E. Klein and G. K. Pullum. Dordrecht: Foris. 1-55.
- McMahon, April M. S. 2000. *Change, chance, and optimality*. Oxford linguistics. Oxford; New York: Oxford University Press.
- Merkle, Ludwig. 1975. *Bairische Grammatik*. München: Hugendubel.
- Mester, Armin. 1994. The quantitative trochee in Latin. *Natural Language and Linguistic Theory* 12:1–61.
- Mori, Yoko. 2002. Lengthening of Japanese monomoraic nouns. *Journal of Phonetics* 30:689–708.
- Nagahara, H. 1994. *Phonological Phrasing in Japanese*. Doctoral dissertation. Department of Linguistics, UCLA.

- Nespor, Marina, and Irene Vogel. 1986. *Prosodic Phonology*. Dordrecht: Foris.
- Oda, Kenji. 2006. The accentuation patterns of nominal compounds in Japanese. *Toronto Working Papers in Linguistics* 26: 23–64.
- Peperkamp, Sharon. 1997. *Prosodic Words*. Ph.D. Dissertation, Universiteit van Amsterdam. Den Haag: Holland Institute of Generative Linguistics.
- Pierrehumbert, Janet, and Mary Beckman. 1988. *Japanese Tone Structure*. LI Monograph Series No. 15. Cambridge, MA: MIT Press.
- Prince, Alan, and Paul Smolensky. 1993. *Optimality theory: Constraint interaction in generative grammar*. Ms. Brunswick, New Jersey, and Boulder, Colorado: Rutgers University and

- University of Colorado, Boulder. [Malden, Mass.: Blackwell, 2004.].
- Poser, William J. 1984. *The Phonetics and Phonology of Tone and Intonation in Japanese*, MIT: Doctoral dissertation.
- Rawlins, Kyle. 2004. Rhotic and nonrhotic dialects of English. Ms. Santa Cruz, CA: UC Santa Cruz.
- Shattuck-Hufnagel, Stefanie, Marie Ostendorf, and Ken Ross. 1994. Stress shift and early pitch accent placement in lexical items in American English. *Journal of Phonetics* 22:357–388.
- Saito, Mamoru. 1985. *Some asymmetries in Japanese and their theoretical implications*. Doctoral Dissertation. Department of Linguistics and Philosophy, Massachusetts Institute of Technology.
- Sakano, Nobuhiko. 1996. *7–5 chou no nazo-wo toku*. Tokyo, Japan: Taishukan.

- Schreuder, Maartje. 2006. *Prosodic Processes in Language and Music*. PhD Dissertation, Rijksuniversiteit Groningen, The Netherlands. [<http://roa.rutgers.edu/view.php3?id=1186>.]
- Schreuder, Maartje, and Dicky Gilbers. 2004. Recursive Patterns in Phonological Phrases. In *Proceedings of Speech Prosody 2004*, eds. Bernard Bel and Isabelle Marlien. Nara, Japan: ISCA (SproSig). 341–344.
- Selkirk, Elisabeth. 1984. *Phonology and Syntax: The Relation between Sound and Structure*. Cambridge, MA: MIT Press.
- Selkirk, Elisabeth. 1995. The prosodic structure of function words. In *Papers in Optimality Theory*, eds. Jill Beckman, Laura Walsh Dickey and Suzanne Urbanczyk, 439–470. Amherst, MA: GLSA.
- Selkirk, Elizabeth. 2000. The interaction of constraints on prosodic phrasing. In *Prosody, theory and experiment: studies*

- presented to Gösta Bruce*, ed. Merle Home, 231–261.
Dordrecht, The Netherlands: Kluwer Academic Publishers.
- Selkirk, Elizabeth. 2005. Comments on intonational phrasing in English. In *Prosodies: Selected Papers from the Phonetics and Phonology in Iberia Conference, 2003 (Phonetics and Phonology Series)*, eds. Sónia Frota, Marina Vigário and Maria João Freitas. Berlin & New York: Mouton de Gruyter.
- Selkirk, Elisabeth, and Koichi Tateishi. 1988. Constraints on minor phrase formation in Japanese. In *Papers from the 24th Annual Regional Meeting of the Chicago Linguistic Society*, 316–336. Chicago: Chicago Linguistic Society.
- Selkirk, Elisabeth, and Koichi Tateishi. 1991. Syntax and downstep in Japanese. In *Interdisciplinary Approaches to Language: Essays in Honor of S.-Y. Kuroda*, eds. C. Georgopoulos and R. Ishihara, 519–544. Dordrecht: Kluwer.

- Selkirk, Elizabeth, Takahito Shinya, and Mariko Sugahara. 2003. Degree of Initial Lowering in Japanese as a Reflex of Prosodic Structure Organization. In *Proc.15th ICPPhS, Barcelona, Spain*. 491–494.
- Shinya, Takahito, Elisabeth Selkirk, and Shigeto Kawahara. 2004. Rhythmic boost and recursive minor phrase in Japanese. In *Proceedings of the second international conference on speech prosody*.
- Sivertsen, Eva. 1960. *Cockney Phonology*. Oslo Studies in English, No. 8. Oslo: Oslo University Press.
- Tanaka, Shin-ichi. 2001. Factorial typology in Japanese compound accentuation. Ms. Handout of talk presented at the Phonological Association in Kansai, February 15, 2001.
- Tateishi, Koichi. 1989. Theoretical implications of the Japanese musician's language. In *Proceedings of WCCFL 8*, eds. E. J.

- Fee and K. Hunt. Stanford: Stanford Linguistic Association. 384–398.
- Truckenbrodt, Hubert. 1995. *Phonological Phrases: Their Relation to Syntax, Focus, and Prominence*, Massachusetts Institute of Technology: Doctoral dissertation.
- Truckenbrodt, Hubert. 1997. Correspondence of syntactic and phonological phrases. Ms.: Rutgers University.
- Truckenbrodt, Hubert. 2002. Upstep and embedded register levels. *Phonology* 19:77–120.
- Truckenbrodt, Hubert. 2006. The syntax-phonology interface. Ms. Tübingen: Tübingen University. To appear in Paul de Lacy (ed.), *The Cambridge Handbook of Phonology*, Cambridge: Cambridge University Press.
- Trudgill, Peter. 1974. *The Social Differentiation of English in Norwich*. Cambridge, U.K.: Cambridge University Press.

- Uffmann, Christian. 2003. A new look at intrusive [r]. Ms. Handout for a seminar at the University of Essex.
<http://www.staff.uni-marburg.de/~uffmann/ufo.htm#ank3>.
- Uffmann, Christian. 2005. Intrusive [r] and optimal epenthetic consonants. Ms. Marburg: Philipps-Universität Marburg.
<http://www.staff.uni-marburg.de/%7Euffmann/language-science.pdf>.
- Ussishkin, Adam Panter. 2000. *The Emergence of Fixed Prosody*. Department of Linguistics, UC Santa Cruz: Doctoral Dissertation.
- Ussishkin, Adam Panter. 2005. A fixed prosodic theory of nonconcatenative templatic morphology. *Natural Language and Linguistic Theory* 23:169–218.
- van den Berg, Rob, Carlos Gussenhoven, and Toni Rietveld. 1992. Downstep in Dutch: implications for a model. In *Papers in*

- laboratory phonology, vol. ii: Gesture, segment, prosody, eds. Gerard J. Dochtery and D. Robert Ladd. Cambridge: Cambridge University Press. 335–358.
- Venditti, Jennifer J. 1997. Japanese ToBI Labelling Guidelines. In *Papers from the Linguistics Laboratory. Ohio State University Working Papers in Linguistics, vol. 50*, eds. K. Ainsworth-Darnell and M. D'Imperio, 127–162. Columbus, Ohio.
- Wagner, Michael. 2005. *Prosody and Recursion*. Doctoral dissertation. Department of Linguistics and Philosophy, MIT.
- Wells, John C. 1982. *Accents of English*. Cambridge, U.K.: Cambridge University Press.
- Wells, John C. 1991. The Cockneyfication of RP?
<http://www.phon.ucl.ac.uk/home/estuary/cockneyf-sil.htm>.

Junko Ito
ito@ucsc.edu

Armin Mester
mester@ucsc.edu

Department of Linguistics
Adlai E. Stevenson College
University of California, Santa Cruz
Santa Cruz, CA 95060